



H19 Series BASO® Automatic Shutoff Pilot Gas Valve/ BGX Series Remote Electrical Automatic Shutoff Gas Valve

Application

The H19 and BGX Series pilot valves provide safe lighting and complete shutoff of main burner gas and pilot gas in the event that the flame heating the thermocouple is extinguished (H19A_ applications only). Applications include heaters, commercial cooking equipment and similar applications. The H19ME and BGX valves are for use on catalytic heater applications. The BGX valve is designed to be used in remote catalytic applications.

Installation

IMPORTANT: Only qualified personnel should install or service BASO® Gas Products products. These instructions are a guide for such personnel. Carefully follow all instructions in this document and all instructions for the appliance.

IMPORTANT: Make all gas installation in accordance with applicable local, national, and regional regulations.



CAUTION: Risk of Electric Shock.

Disconnect power supply before making electrical connections to avoid electric shock.

Note: In applications that do not require electrical power, disregard the previous caution.



WARNING: Risk of Explosion or Fire.

Shut off the gas supply at the main manual shutoff valve before installing or servicing the valve. Failure to shut off the gas supply can result in the release of gas during installation or servicing, which can lead to an explosion or fire, and may result in severe personal injury or death.

IMPORTANT: Verify that the valve is installed only in applications where the specified maximum ambient (surface) temperature and maximum operating pressures do not exceed the limits in the *Technical Specifications* section.

To install the H19 or BGX valve:

1. Shut off power to the appliance (if applicable).
2. Shut off the gas at the main manual shutoff valve.
3. Ensure that the gas flows through the valve body in the direction indicated by the arrow on the valve body. If the valve is installed with the gas flow in the opposite direction of the arrow or IN designation, leakage can occur.

IMPORTANT: Do not use a wrench on any surface other than the casting flats provided at the inlet and outlet ends of the valve body. The valve may be damaged in the mounting process if a wrench is used on any other surface. Using a wrench incorrectly may void the warranty.

4. Mount the valve to the pipework. The H19 or BGX valve may be mounted in any convenient position. Use an approved pipe joint sealing compound on male threads before assembling. Remove excess compound after mounting the valve to the pipework. Threads of the pipe and nipples must be smooth and free of tears and burrs. Steam clean all piping to remove foreign substances such as cutting oil or thread chips. A sediment trap should also be installed in accordance with the National Fuel Gas Code (Z223.1/NFPA 54). See Figure 1 and Figure 2.

5. Attach the thermocouple securely to the pilot burner (H19A_ valves only). Connect the thermocouple lead nut to the power unit terminal. Tighten the thermocouple lead nut finger tight plus an additional maximum of 1/8 turn. **Do not overtighten.**
6. Attach the pilot gas line to the pilot burner fitting and to the pilot gas outlet of the H19 valve (H19A_ valves only).

! WARNING: Risk of Explosion or Fire.
 Verify that there are no gas leaks by testing with appropriate equipment. Never use a match or lighter to test for the presence of gas. Failure to test properly can lead to an explosion or fire and may result in severe personal injury or death.

7. Check for leakage:
 - a. Shut off the gas at the main manual shutoff valve and open the pressure connection between the manual shutoff valve and the H19 or BGX valve.
 - b. Connect air tubing with a maximum pressure of 1-1/2 times the valve's maximum operating pressure (as indicated on the valve) to the opened pressure connection.
 - c. Paint all valve body connections with a rich soap and water solution.
 If bubbles occur, this is an indication of a leak. To stop a leak, tighten joints and connections. Replace the part if the leak cannot be stopped.
 If bubbles do not occur, remove the air tubing and close the pressure connection.
8. Perform the *Checkout* section before leaving the installation.

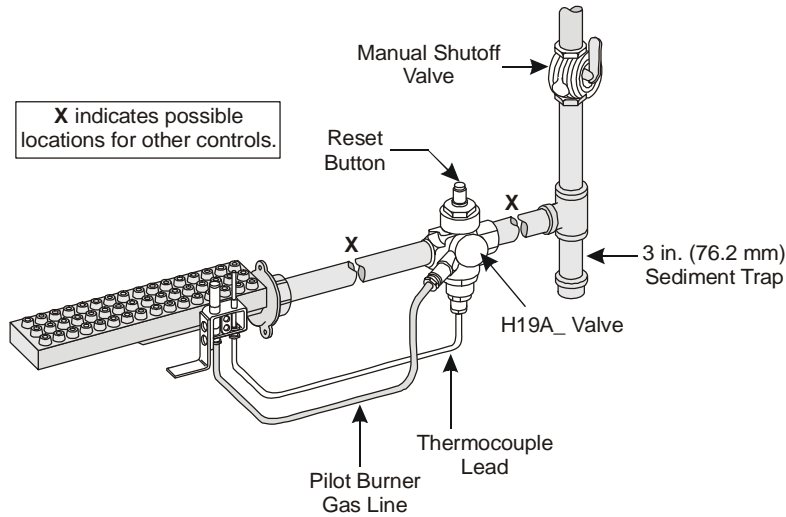

Figure 1: Typical H19A_ Installation

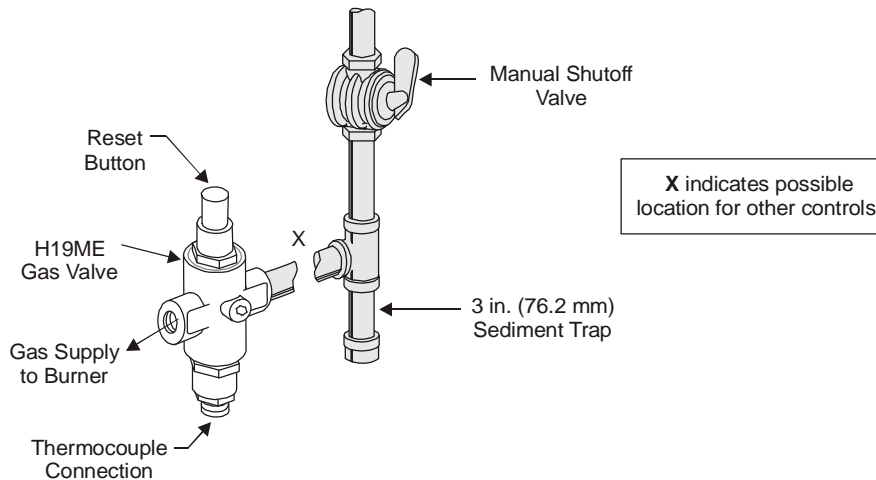

Figure 2: Typical H19ME Installation

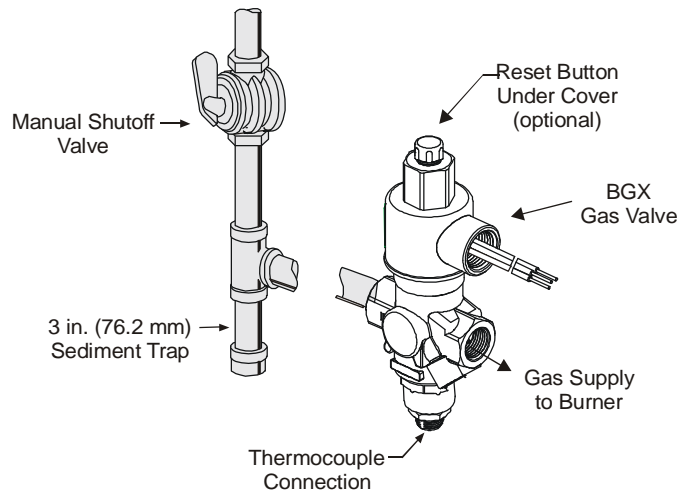

Figure 3: Typical BGX Installation

Setup and Adjustments

Checkout

Make sure all components are functioning properly by performing the following procedure.

Checkout for H19A_ Valves



WARNING: Risk of Explosion or Fire.

Follow this or an equivalent checkout procedure after installation. Before leaving the installation, verify that the gas valve functions properly and that the system has no gas leaks. Gas leaks can lead to an explosion or fire, and may result in severe personal injury or death.

1. Test all joints and connections for leaks with a rich soap and water solution. If leaks occur, see Step 7 in the *Installation* section.
2. Close the manual shutoff valve and pilot valve and wait at least 5 minutes for unburned gas to escape from the appliance, then reopen the valves.
3. Push the reset button of the BASO® power unit and light the pilot burner. Continue to hold the reset button for 30 to 45 seconds or until the pilot remains burning when the reset button is released.
4. Set the thermostat to the highest setting. The main burner ignites from the pilot burner.
5. Set the thermostat to the lowest setting. The main burner extinguishes.
6. Extinguish all flames by closing the manual shutoff valve. Verify that the main valve drops out within 90 seconds. Reopen the valve.

7. Relight the pilot burner.
8. Check the millivoltage (mV) output of the thermocouple and milliampere (mA) dropout range at the BASO power unit terminal to be sure that they meet the values in Table 1 and Table 2. Step-by-step procedures for these checks are included with the *Y99AB-4 BASO Test Kit Application Note*.
9. Observe at least three complete operating cycles to make sure that all components are functioning correctly.
10. Return the thermostat to a normal temperature setting before leaving the installation.

Table 1: Thermocouple Output

Thermocouple		mV Range	
Lead Type	Turn Down	Normal	Not Less Than
K15	4 mV	20-28	15
K16	4 mV	25-35	17
K19	4 mV	25-35	17

Table 2: Dropout Range

Series Number	mA Range of Power Unit Assembly	
	Low	High
H19A_	100	300
H19ME	45	165
BGX	45	165

Checkout for Catalytic Heater Applications



WARNING: Risk of Explosion or Fire.

Follow this or an equivalent checkout procedure after installation. Before leaving the installation, verify that the gas valve functions properly and that the system has no gas leaks. Gas leaks can lead to an explosion or fire, and may result in severe personal injury or death.

1. Turn on the main gas supply to the system.
 2. If the heater is equipped with a thermostat, set the thermostat to the highest setting.
 3. Turn on the power to the electrical elements.
 4.
 - a. Wait 15 minutes. H19ME model, depress the reset button of the BASO power unit. The button should return to the original position and internally open the valve allowing gas to flow to the heater.
 - b. Wait 15 minutes. BGX models energize depending on your voltage (12 Vdc or 24 Vdc) to activate the power unit, allowing power to stay on for 30 – 45 seconds. After releasing power to the solenoid, the internal seat should remain open, allowing gas to flow to the heater.
 - c. Wait 15 minutes. Use manual override button (option) on some BGX models by depressing the reset (see Figure 6) if there is no power to the solenoid. Releasing pressure on the reset allows the button to return to its original position and internally open the valve, allowing gas to flow to the heater.
- Note:** If the valve does not stay open when the reset button is released, it may be necessary to wait an additional few minutes and then depress the reset or activate again.
5. When the catalytic reaction is well established, turn off the power to the electrical elements (H19ME and BGX).
 6. Check the millivoltage output of the thermocouple and milliampere dropout range at the BASO power unit terminal to be sure that they meet the values in Table 1 and Table 2. Step-by-step procedures for these checks are included with the *Y99AB-4 BASO Test Kit Application Note (Part No. 24-8711-838)*.

Pilot Gas Adjustment

A rotor B valve is provided on certain models to manually adjust pilot flame size. Off and On positions are indicated on the valve. By slowly turning the adjustment knob, a desirable flame can be obtained.

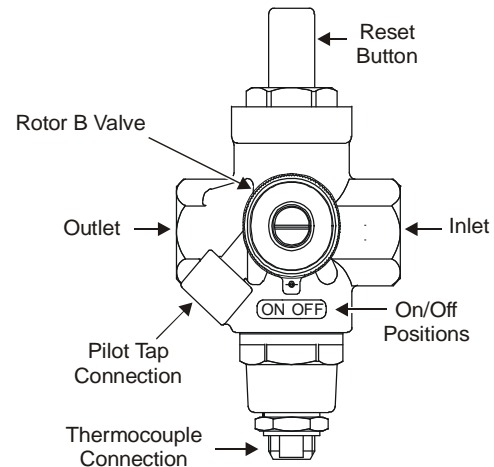

Figure 4: Typical H19 Valve with Rotor Valve

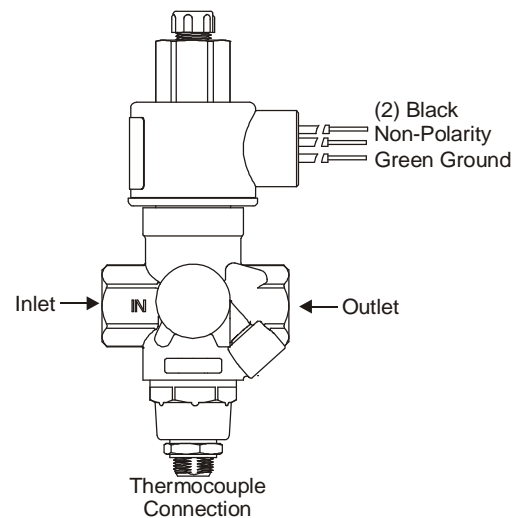

Figure 5: BGX Series

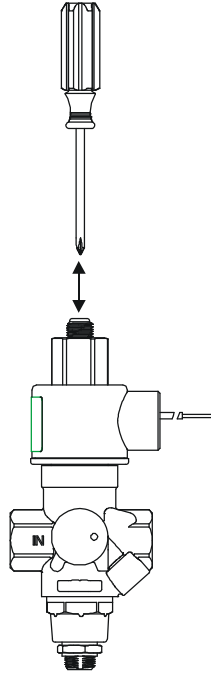

Figure 6: Manual Override Operation

Pilot Servicing

If pilot flame problems occur, check the following:

- If the pilot flame burns yellow, it may be due to dirt or lint covering the lower portion of the pilot burner. Remove this using a soft brush or a vacuum.
- A flame approximately 1/2 in. (12.7 mm) high must surround the thermocouple tip (Figure 7).
- Because this is an electrical connection, the thermocouple lead connection to the BASO power unit must be clean and free of grease.

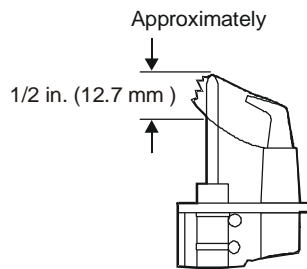

Figure 7: Flame Position (H19A_ only)

Repairs and Replacement



WARNING: Risk of Explosion or Fire.

Shut off the gas supply at the main manual shutoff valve before installing or servicing the H19. Failure to shut off the gas supply can result in the release of gas during installation or servicing, which can lead to an explosion or fire, and may result in severe personal injury or death.

Field repairs **must not** be made to the H19 valve. If the thermocouple meets the output in Table 1 and the valve does not function, replace the entire valve. Any attempt to repair this assembly voids the manufacturer's warranty. For a replacement valve, contact the original equipment manufacturer or the nearest BASO Gas Products distributor.

Technical Specifications

Product	H19 Series BASO Automatic Shutoff Pilot Gas Valve BGX Series Remote Electrical Automatic Shutoff Gas Valve
Maximum Operating Pressure	0.5 psi (35 mbar)
Valve Body	Aluminum
Permissible Ambient (Surface) Temperature	H19A_ 32 to 150°F (0 to 66°C) H19ME -40 to 150°F (-40 to 66°C) BGX -40 to 150°F (-40 to 66°C)
Recommended Thermocouple Lead Length	K15: 12 to 48 in. (305 to 1,220 mm) K16: 12 to 72 in. (305 to 1,830 mm) K19: 18 to 72 in. (457 to 1,830 mm)
Inlet and Outlet Pipe Size	3/8 x 3/8 in. NPT
Types of Gas	Natural, Liquefied Petroleum (LP), and LP gas-air mixtures
Packaging	Bulk pack supplied to original equipment manufacturer (individual pack optional)
Bulk Pack Quantity	H19: 60 BGX: 30
Bulk Pack Weight	30 lb (14 kg)
Agency Listings	CSA (AGA/CGA) Certificate Number 229521-1656106 (BGX Pending CSA Approval) UL Recognized File Number MH2926 (H19AA only)
Specification Standards	ANSI Z21.78, CSA 6.20 ANSI Z21.21, CSA 6.5 ANSI Z21.20, CAN1-6.4 UL Standard 372

Performance specifications are nominal and conform to acceptable industry standards. All agency certification of BASO products is performed under dry and controlled indoor environmental conditions. Use of BASO products beyond these conditions is not recommended and may void the warranty. Product must be protected if exposed to water (dripping, spraying, rain, etc.) or other harsh environments. The original equipment manufacturer or end user is responsible for the correct application of BASO products. Consult BASO Gas Products LLC for questionable applications. BASO Gas Products LLC shall not be liable for damages or product malfunctions resulting from misapplication or misuse of its products.

Refer to the *H19 Series BASO Automatic Shutoff Pilot Gas Valve Product Bulletin (BASO-PB-H19)* for necessary information on operating and performance specifications of this product.



BASO Gas Products LLC

1007 South 12th Street
PO Box 170
Watertown, WI 53094
1-877-227-6527 (1-877-BASOGAS)

www.baso.com
Printed in U.S.A.