



BGD258 Series BASOTROL® CE Approved Class A Gas Valve

Installation

IMPORTANT: These instructions are intended as a guide for qualified personnel installing or servicing BASO Gas Products. Carefully follow all instructions in this bulletin and all instructions on the appliance. Limit repairs, adjustments, and servicing to the operations listed in this bulletin or on the appliance.

! WARNING: Risk of Fire or Explosion.
The system must meet all applicable local, national, and regional regulations. Improper installation may cause gas leaks, explosions, property damage, and injuries.

! WARNING: Risk of Fire or Explosion.
To prevent leakage of upstream gas, shut off the gas supply at the main manual shutoff valve before installing or servicing the BGD258 valve. Failure to shut off the gas supply can result in the release of gas during installation or servicing, which can lead to an explosion or fire, and may result in severe personal injury or death.

Mounting

! CAUTION: Risk of Equipment Damage.
To prevent damage to the valve when mounting to pipework, do not use a wrench on any surface other than the casting flats provided at the inlet and outlet ends of the valve body.

To install the BGD258 valve:

1. Ensure that the specified maximum ambient (surface) temperature is not exceeded (see the *Technical Data* section).
2. Ensure that the power supply voltage is compatible with the required control valve voltage.
3. Shut off the gas at the main manual shutoff valve.
4. When installing the valve on the manifold, ensure that the gas flows through the valve body in the direction indicated by the arrow on the valve body. If the valve is installed with the gas flow in the opposite direction of the arrow, leakage can occur.
5. Mount the valve to the pipework. The BGD258 valve may be mounted on a horizontal manifold with the solenoid coils pointed up (vertical) or in any position not exceeding 90° from the vertical. The valve also may be mounted on a vertical manifold in any position around its axis (see Figure 1). Do not install the solenoid coil upside down. Install vertically wherever possible.

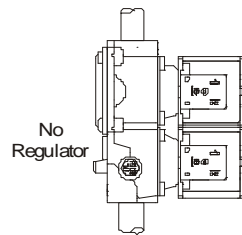
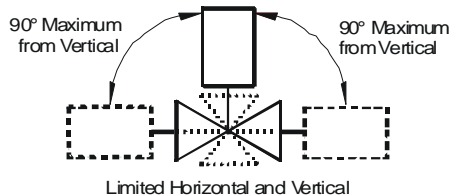

Vertical mounting may be 360° around its axis with the gas flow either up or down, but always in the direction of the arrow.

Figure 1: BGD258 Valve Mounting Positions

6. Use an approved pipe joint sealing compound on the male threads before assembly. Remove excess compound after mounting the valve to the pipework. Threads of the pipe and nipples must be smooth and free of tears and burrs. Steam clean all piping to remove foreign substances such as cutting oil or thread chips.
7. If you desire to measure the outlet pressure, use the bottom cast pressure test fitting or use the Y99AX-1 pressure test fitting (see Figure 2) and an approved pipe joint compound on the male threads and screw the fitting into either side of the valve, which ever side is convenient, replacing the pressure tap plug.
8. Check for leakage.
 - a. Shut off the gas at the main manual shutoff valve and open the pressure connection between the manual shutoff valve and the BGD258 valve.
 - b. Connect air tubing with a maximum pressure of 1-1/2 times the valve's maximum operating pressure (as indicated on the valve) to the opened pressure connection.
 - c. Paint all valve body connections and bleed hole with a rich soap and water solution.
 If bubbles occur, this is an indication of a leak. To stop a leak, tighten joints and connections. Replace the part if the leak cannot be stopped.
 If bubbles do not occur, remove the air tubing and close the pressure connection.
9. Make wiring connections. Refer to the *Wiring* section for specific wiring instructions.
10. To measure the outlet pressure, turn the screw in a counterclockwise direction one or two turns in the fitting and fit a 9 mm diameter flexible tube over the fitting. Proceed to operate the valve and observe the outlet pressure.
11. Once the operation of the valve and the observation of the outlet pressure is complete, turn off power to both valve solenoids. Remove the flexible tube and tighten the needle screw by turning it clockwise with a slotted screwdriver until hand tight, sealing the bleed hole.

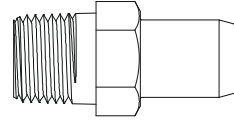

Figure 2: Y99AX-1 Pressure Test Fitting

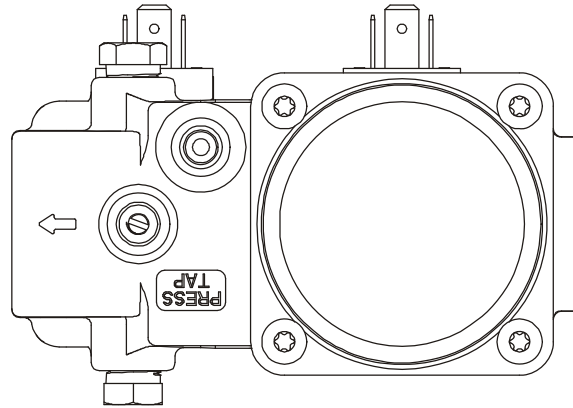

Figure 3: Underside of Valve

12. Before leaving the installation, observe at least three complete operating cycles to ensure that all components are functioning correctly. Make sure bleed hole is leak tight (review 8c for leakage test).

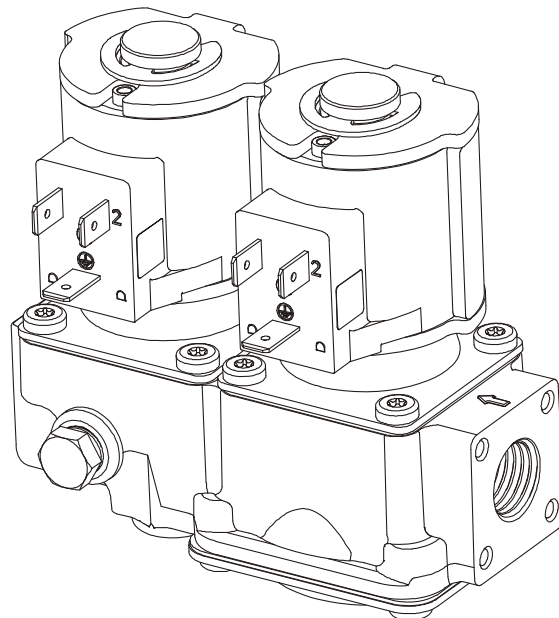

Figure 4: BGD258 Gas Valve

Wiring



WARNING: Risk of Shock.

Disconnect the power supply before making electrical connections to avoid electrical shock or equipment damage. Ensure that the operating voltage is identical to the information on the product identification label.



CAUTION: Risk of Equipment Damage.

For 12 VDC applications, the ground wire must **not** be connected to prevent possible grounding of the 12 VDC power supply transformer secondary.

The BGD258 valve is supplied with 3-tab or 2-tab electrical connections. The pins of the solenoid coil are male tag terminals, and electrical connections should be made using 1/4 in. (6.35 x 0.8 mm) female, fully insulated push-on terminals. The earth ground is clearly labeled.

The electrical wiring to a twin solenoid valve from an electronic intermittent proven pilot ignition system is comprised of two lines; a common and an independent earth ground. Wiring can be done using a single 4-wire cable. The wiring connections for a 4-wire cable are shown in Figure 5.

Route the electrical cable for the valve solenoid from the burner sequence control to the valve and make wiring connections in accordance with Figure 5.

Note: Electrical connections can also be made using pre-wired electrical plugs (DIN 43650 [ISO 4400]).

All wiring must be in accordance with national and local electrical codes and regulations.

Setup and Adjustments

IMPORTANT: All adjustments must be made in conjunction with the gas appliance and in accordance with the appliance manufacturer's instructions. Only authorized personnel should make adjustments.



WARNING: Risk of Fire or Explosion.

The minimum flow rate of the valve must not be adjusted below the minimum safe working rate of the appliance.

Repairs and Replacement

Table 1: Replacement Solenoid Coil

Part Number	Description
RSDA16A-12	12 VDC; 50/60 Hz; 2-pin 15 VA Coil
RSDA16A-25	25 VAC; 50/60 Hz; 3-pin 15 VA Coil
RSDA16A-120	120 VAC; 50/60 Hz; 3-pin 15 VA Coil
RSDA16A-240	240 VAC; 50/60 Hz; 3-pin 15 VA Coil

Field repairs other than solenoid coil replacement **must not** be made to the BGD258 valve.

Any attempt to repair this assembly voids the manufacturer's warranty. For a replacement valve, contact the original equipment manufacturer or the nearest BASO Gas Products distributor.

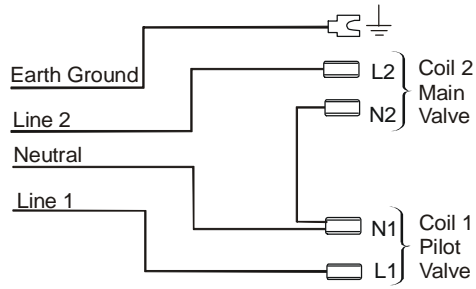

Twin Solenoid Wiring Using 4-Wire Cable

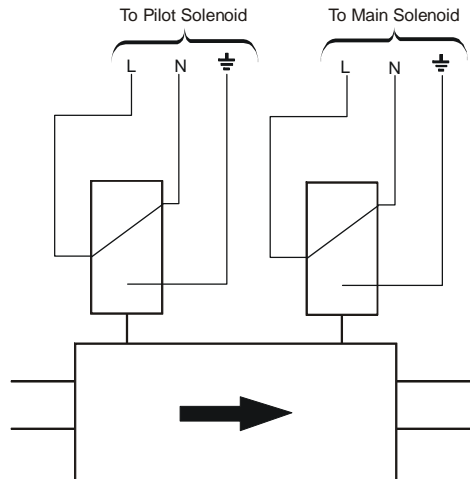
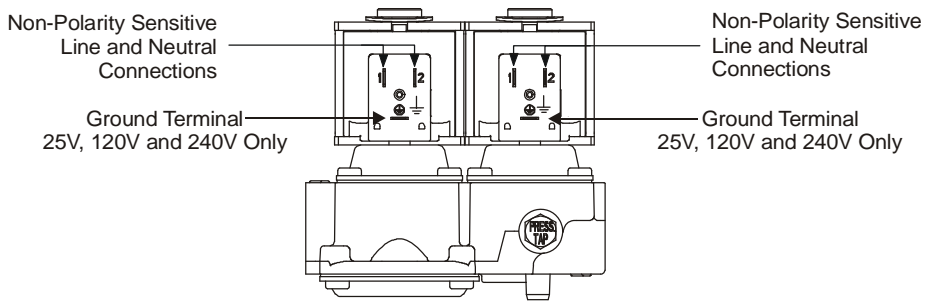

Figure 5: 3-Pin Electrical Connections

Technical Data

Product	BGD258 Series BASOTROL CE Approved Gas Valve	
Types of Gas	2nd (Natural Gas), and 3rd (LP Gas) Family Gases	
Permissible Ambient (Surface) Temperature	-29 to 79°C (-20 to 175°F)	
Electrical Ratings	12 VDC, 1.0A (not CE approved) 25 VAC, 50/60 Hz, 0.595A 120 VAC, 50/60 Hz, 0.13A 240 VAC, 50/60 Hz, 0.063A	
Maximum Operating Pressure	North America:	2 psi
	Europe:	138 mbar
Reverse Pressure Ratings	150 mbar (15 kPa) (60 in. W.C.); Class A (EN 161)	
Inlet Pipe Size	3/8 in. NPT, 1/2 in. NPT, 3/8 Rp or 1/2 Rp	
Outlet Pipe Size	3/8 in. NPT, 1/2 in. NPT, 3/8 Rp or 1/2 Rp	
Valve Torsion Group	Group 2 (EN 161)	
Pressure Connection	1/8 in. NPT or M5 x 0.8 thread	
Dirt Strainer	0.9 mm (0.036 in.) Mesh	
Operating Time Rating	100% Continuous	
Valve Timings	Closing Time	≤1 Second
	Opening Time	≤1 Second
	Dead Time	≤1 Second
Power Ratings	15 VA per Coil	
Electrical Connections	3-Tab Solenoid Coil	2 x 6.35 mm (1/4 in) Terminals + 6.35 mm (1/4 in) Earth Ground Terminal
	2-Tab Solenoid Coil	2 x 6.35 mm (1/4 in) Terminals
Coil Insulation Class	Class F	
Packaging	Bulk pack supplied to original equipment manufacturer (individual pack optional).	
Bulk Pack Quantity	32 per carton	
Bulk Pack Weight	36 kg (79 lb) per carton	
Agency Listings	CSA (AGA/CGA) Certificate Number Pending EC Type Examination Certificate Number Pending	
Specification Standards	EN 161 Standards Complying with EMC Directive Standards Complying with Low Voltage Directive ANSI Standards Z21.21 Canadian Standards CAN1-6.5	

Performance specifications are nominal and conform to acceptable industry standards. All agency certification of BASO products is performed under dry and controlled indoor environmental conditions. Use of BASO products beyond these conditions is not recommended and may void the warranty. Product must be protected if exposed to water (dripping, spraying, rain, etc.) or other harsh environments. The original equipment manufacturer or end user is responsible for the correct application of BASO products. Consult BASO Gas Products LLC for questionable applications. BASO Gas Products LLC shall not be liable for damages or product malfunctions resulting from misapplication or misuse of its products.

Refer to the *BGD258 Series CE Approved Gas Valve Product Bulletin (BASO-PB-BGD258)* for necessary information on operating and performance specifications of this product.

1007 South 12th Street
PO Box 170
Watertown, WI 53094
1-877-227-6427 (1-877-BASOGAS)

www.baso.com
Printed in U.S.A.