



## G93 Series BASOTROL® Combination Automatic Gas Valve

### Application

The G93 valves are suitable for use with natural gas, Liquefied Petroleum (LP) gas, or LP gas-air mixtures. Typical applications include central heating units, unit heaters, commercial clothes dryers, and similar applications.

### Installation

**IMPORTANT:** Only qualified personnel should install or service BASO Gas Products products. These instructions are a guide for such personnel. Carefully follow all instructions in this document and all instructions for the appliance.

**IMPORTANT:** Make all gas installations in accordance with applicable local, national, and regional regulations.



**CAUTION: Risk of Electric Shock.**

Disconnect power supply before making electrical connections to avoid electric shock.



**WARNING: Risk of Explosion or Fire.**

Shut off the gas supply at the main manual shutoff valve before installing or servicing the G93. Failure to shut off the gas supply can result in the release of gas during installation or servicing, which can lead to an explosion or fire, and may result in severe personal injury or death.



**WARNING: Risk of Explosion, Fire, or Electric Shock.** Label all wires before they are disconnected when replacing or servicing the G93. Wiring errors can cause improper or dangerous operation and may result in an explosion, fire, or electric shock leading to severe personal injury or death.

**IMPORTANT:** Verify that the valve is installed only in applications where the specified maximum ambient (surface) temperature and maximum operating pressures will not exceed the limits in the *Technical Specifications* section.

To install the G93 valve:

1. Shut off power to the appliance.
2. Shut off the gas at the main manual shutoff valve.
3. Label each wire with the correct terminal designation prior to disconnection.
4. Compare the voltage on the valve with the power source voltage to ensure the correct unit is being installed. For valves with 25-volt coils, use a National Electrical Code (NEC), Class 2 transformer.  
**Note:** The transformer must be mounted to a grounded metal enclosure.
5. Ensure that the gas flows through the valve body in the direction indicated by the arrow on the valve body. If the valve is installed with the gas flow in the opposite direction of the arrow, leakage can occur.

**IMPORTANT:** Do not use a wrench on any surface other than the casting flats provided at the inlet and outlet ends of the valve body. The G93 may be damaged in the mounting process if a wrench is used on any other surface. Using a wrench incorrectly may void the warranty.

6. Mount the G93 on a horizontal manifold with the magnetic operator pointed up (vertical) or in a position not exceeding 90° from vertical. The valve may also be mounted on a vertical manifold in any position around its axis (Figure 1).

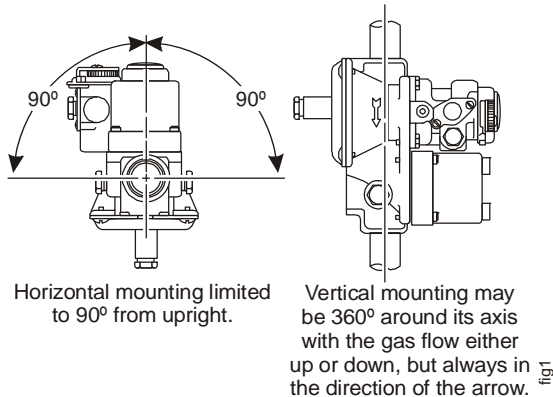

**Figure 1: G93 Mounting Positions**

7. Mount the valve to the pipework. Use an approved pipe joint sealing compound on the male threads before assembly. Remove excess compound after mounting the valve to the pipework. Threads of the pipe and nipples must be smooth and free of tears and burrs. Steam clean all piping to remove foreign substances such as cutting oil or thread chips. A sediment trap should also be installed in accordance with the National Fuel Gas Code (ANSI Z223.1).
8. Attach the thermocouple securely to the pilot burner, and screw the terminal end to the BASO® power unit terminal on the valve. Make sure this connection is clean. Tighten the thermocouple lead nut finger tight, plus a maximum of 1/8 turn. Do not overtighten.

9. Pilot gas connections.
  - a. **Internal Pilot Gas Valve Models** receive pilot gas internally from the valve body.

**Note:** Pilot gas flow comes out of either gas valve top housing ports.

On internal pilot gas valve models, plumb the pilot burner fitting to either of the pilot gas ports on the valve. Plug the unused pilot gas port on the gas valve. **See Figure 2 and Figure 3.**



**WARNING: Risk of Explosion or Fire.**

Never connect an external gas line to an internal pilot gas model. Pilot gas would flow freely in one port and out the other, which could lead to an explosion or fire and may result in severe personal injury or death.



**WARNING: Risk of Explosion or Fire.**

Verify that there are no gas leaks by testing with appropriate equipment. Never use a match or lighter to test for the presence of gas. Failure to test properly can lead to an explosion or fire and may result in severe personal injury or death.

10. Check for leakage:
  - a. Shut off the gas at the main manual shutoff valve and open the pressure connection between the manual shutoff valve and the G93 valve.
  - b. Connect air tubing with a maximum pressure of 1-1/2 times the valve's maximum operating pressure (as indicated on the valve) to the opened pressure connection.
  - c. Paint all valve body connections with a rich soap and water solution.

If bubbles occur, this is an indication of a leak. To stop a leak, tighten joints and connections. Replace the part if the leak cannot be stopped.

If bubbles do not occur, remove the air tubing and close the pressure connection.
11. Perform the *Checkout* section before leaving the installation.

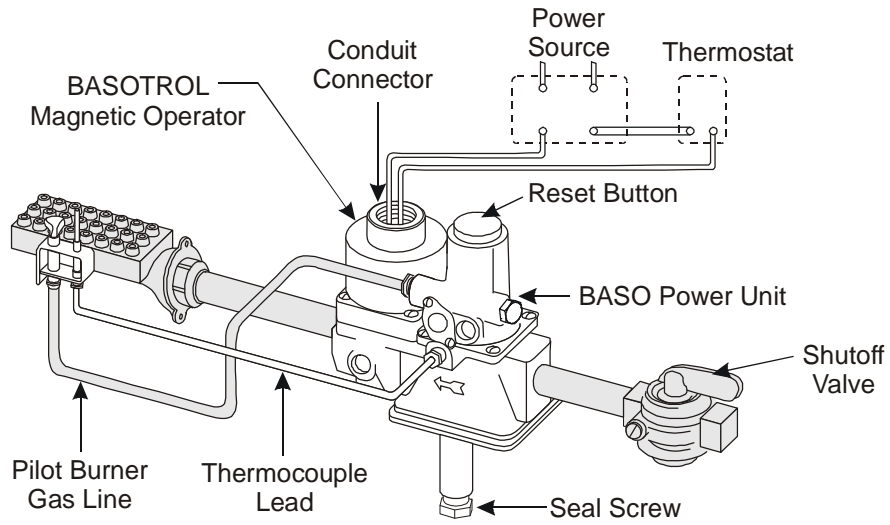

**Figure 2: Typical Installation for Internal Pilot Gas Flow**

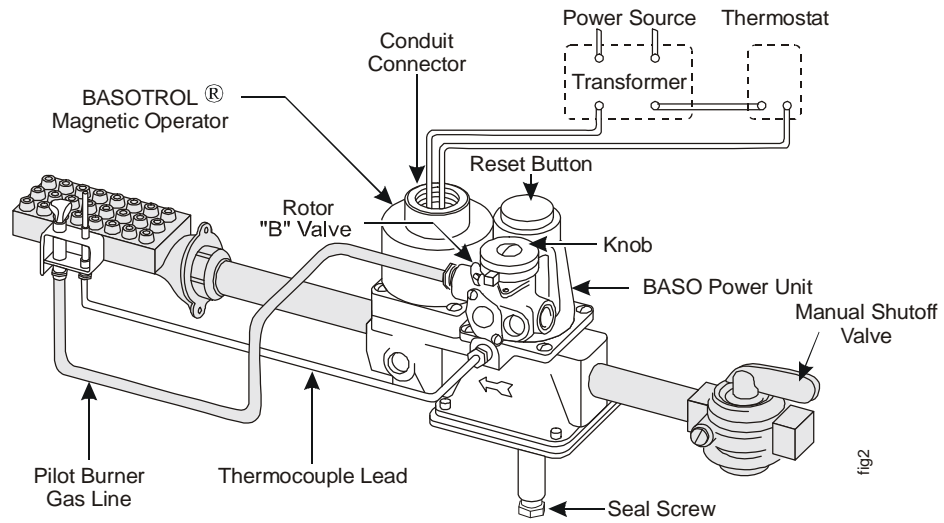

**Figure 3: Typical Installation Showing Internal and Rotor B Valve**

## Setup and Adjustments

### Checkout



**WARNING: Risk of Explosion or Fire.**

Follow this or an equivalent checkout procedure after installation. Before leaving the installation, verify that the gas valve functions properly and that the system has no gas leaks. Gas leaks can lead to an explosion or fire, and may result in severe personal injury or death.

Make sure all components are functioning properly by performing the following test:

1. Test all joints and connection for leaks with a soap solution.
2. Close the main upstream shutoff valve and the B valve (applications with a B valve only). Wait at least 5 minutes for unburned gas to escape from the appliance and then reopen the valves.
3. Push the reset button and light the pilot burner. Continue to hold the reset button for 30 to 45 seconds or until the pilot remains lit when the reset button is released.
4. Set the thermostat to the highest setting. The main burner should now ignite from the pilot burner.
5. Extinguish the burner by closing the main upstream manual shutoff valve. Verify that the valve drops out within 90 seconds.
6. Relight the pilot burner.
7. Check the millivoltage (mV) output of the thermocouple and the milliampere (mA) dropout range of the BASO power unit to ensure that they meet the values listed in Table 1 and Table 2. Step-by-step procedures for these checks are included with the *Y99AB-4 BASO Test Kit Application Note (Part No. 24-8711-838)*.
8. Observe at least three complete operating cycles to make sure that all components are functioning properly.
9. Reset the thermostat to the desired setting before leaving the installation.

**Table 1: Thermocouple Output**

Thermocouple		mV Range	
Lead Type	TurnDown	Normal	Not Less Than
K15	4 mV	20-28	15
K16	4 mV	25-35	17
K19	4 mV	25-35	17

**Table 2: Dropout Range**

mA Range of Power Unit Assembly	
Low	High
100	300

### Regulator Adjustment



**WARNING: Risk of Explosion or Fire.**

Do not adjust the minimum flow rate of the valve below the minimum safe working rate of the appliance. This may cause gas leaks, which can lead to an explosion or fire, and may result in severe personal injury or death.

**IMPORTANT:** Refer to and follow any specific instructions issued by the appliance manufacturer with regards to servicing their equipment.

The pressure regulator is adjustable and has been set to a specific customer requirement. If a different setting is desired, follow these instructions:

1. Shut off all gas to the appliance.
2. Turn the thermostat to the lowest setting or Off position.
3. Remove the pressure tap plug at the valve outlet or in the manifold pipe downstream of the valve.
4. Install a manometer or pressure gauge suitable for measuring desired orifice pressure.
5. Remove the seal screw at the end of the regulator stack (Figure 3).
6. Turn the gas on and place the thermostat at the highest setting.
7. Adjust the screw in the regulator stack to the desired reading on the manometer. (Turn clockwise to increase the outlet pressure and counterclockwise to reduce the outlet pressure.)
8. Reinstall the seal screw, which incorporates the proper size hole for venting to the atmosphere. (It may be necessary to cycle the valve several times to verify the desired outlet pressure.)
9. Turn off the gas supply and place the thermostat at the lowest setting.

10. Remove the pressure manometer and reinstall the pressure tap plug.
11. Turn the gas on and set the thermostat at the desired setting.
12. Check for leaks at the pressure tap plug with a soap solution before leaving the site.

### Pilot Gas Adjustment (Applications With a B Valve)

Models with an optional manual rotor pilot valve (**B** valve) allow adjustment of the pilot gas flame. To adjust the pilot gas flame:

1. Loosen the round head screw holding the small adjustment plate beside the manual rotor pilot valve knob, and turn the knob clockwise as far as it goes.
2. Slowly push the adjustment plate in a counterclockwise direction while watching the size of the pilot burner flame.
3. Stop moving the adjustment plate when the pilot flame reaches the proper size, and tighten the round head screw. The rotor pilot valve provides complete on/off operation with the adjustment fixed at the On position.

### Pilot Servicing

If pilot flame problems occur, check the following:

- If the pilot flame burns yellow, it may be due to dirt or lint covering the lower portion of the pilot burner. Remove this using a soft brush or a vacuum.
- A flame approximately 1/2 in. (12.7 mm) high must surround the thermocouple tip (Figure 4).
- Because this is an electrical connection, the thermocouple lead connection to the BASO power unit must be clean and free of grease.

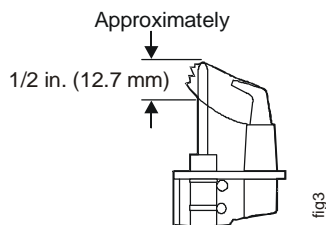

**Figure 4: Flame Position**

## Repairs and Replacement



### CAUTION: Risk of Electric Shock.

Disconnect power supply before making electrical connections to avoid electric shock.



### WARNING: Risk of Explosion or Fire.

Shut off the gas supply at the main manual shutoff valve before installing or servicing the G93. Failure to shut off the gas supply can result in the release of gas during installation or servicing, which can lead to an explosion or fire, and may result in severe personal injury or death.



**WARNING: Risk of Explosion, Fire, or Electric Shock.** Label all wires before they are disconnected when replacing or servicing the G93. Wiring errors can cause improper or dangerous operation and may result in an explosion, fire, or electric shock leading to severe personal injury or death.

Field repairs **must not** be made to the G93 valve. If the thermocouple meets the output listed in Table 1 and the valve does not function, replace the entire valve. Any attempt to repair this assembly voids the manufacturer's warranty. For a replacement valve, contact the original equipment manufacturer or the nearest BASO Gas Products distributor.

## Accessories

**Table 3: G93 Gas Valve Conversion Kits**

Part Number	Regulator Type	Gas Conversion
Y71GF-3	Bottom Adjust	Natural Gas to LP Gas
Y71GF-4	Top Adjust	Natural Gas to LP Gas
Y71QH-2	Top Adjust	LP Gas to Natural Gas
Y71QH-3	Bottom Adjust	LP Gas to Natural Gas
Y71AA-5	Top or Bottom Adjust	Non-Regulation

## Technical Specifications

<b>Product</b>	G93 Series BASOTROL Combination Automatic Gas Valve
<b>Maximum Operating Pressure</b>	0.5 psi (35 mbar)
<b>Valve Body</b>	Aluminum
<b>Permissible Ambient (Surface) Temperature</b>	CSA: 32 to 155°F (0 to 68°C) UL: 32 to 125°F (0 to 52°C)
<b>Available Magnetic Operator Cover Styles</b>	Aluminum side conduit hub Aluminum top conduit hub aluminum top without conduit hub Aluminum side outlet with eyelet Steel top conduit hub Plastic with 1/4 in. (6.35 mm) male quick-connect terminals
<b>Electrical Rating</b>	25 VAC, 60 Hz, 0.3 ampere draw 120 VAC, 60 Hz, 0.05 ampere draw 240 VAC, 60 Hz, 0.03 ampere draw 208/240 VAC, 60 Hz, 0.037 ampere draw
<b>Recommended Thermocouple Lead Lengths</b>	K15: 12 to 48 in. (305 to 1,220 mm) K16: 12 to 72 in. (305 to 1,830 mm) K19: 18 to 72 in. (457 to 1,830 mm)
<b>Wiring Connections</b>	1/4 in. (6.35 mm) male quick-connect terminals or 30 in. (762 mm) lead wires (other lengths are optional)
<b>Regulator Adjustment</b>	3 to 6 in. W.C. (7.5 to 15 mbar), top and bottom adjust regulator, natural gas 6 to 12 in. W.C. (15 to 30 mbar), top adjust regulator, LP gas 8 to 12 in. W.C. (20 to 30 mbar), bottom adjust regulator, LP gas
<b>Inlet and Outlet Body Connections</b>	1/2 x 1/2 in. NPT
<b>Types of Gas</b>	Natural, Liquefied Petroleum (LP), and LP gas-air mixtures
<b>Packaging</b>	Bulk pack supplied to original equipment manufacturer (individual pack optional)
<b>Bulk Pack Quantity</b>	32
<b>Bulk Pack Weight</b>	51 lb (23 kg)
<b>Agency Listing</b>	CSA Certificate Number 229521-1656066 (excludes G93H_ _) UL File Number MH2926
<b>Specification Standards</b>	ANSI Z21.78, CSA 6.20 UL Standard 372 and 429

*Performance specifications are nominal and conform to acceptable industry standards. All agency certification of BASO products is performed under dry and controlled indoor environmental conditions. Use of BASO products beyond these conditions is not recommended and may void the warranty. Product must be protected if exposed to water (dripping, spraying, rain, etc.) or other harsh environments. The original equipment manufacturer or end user is responsible for the correct application of BASO products. Consult BASO Gas Products LLC for questionable applications. BASO Gas Products LLC shall not be liable for damages or product malfunctions resulting from misapplication or misuse of its products.*

Refer to the *G93 Series BASOTROL® Combination Automatic Gas Valve Product Bulletin (BASO-PB-G93)* for necessary information on operating and performance specifications for this product.



BASO Gas Products LLC

1007 South 12th Street  
PO Box 170  
Watertown, WI 53094  
1-877-227-6427 (1-877-BASOGAS)

Published in U.S.A.  
[www.baso.com](http://www.baso.com)