



G960 Series Multi-Functional Gas Control Valve

The G960 Series multi-function gas valve is a combination main and pilot valve intended for use in conjunction with solid-state sequence control units on direct burner or intermittent pilot ignition systems.

The G960 valve can be used with natural gas, Liquefied Petroleum (LP) gas, and LP-air mixed gas. Typical applications include central heating units, makeup air heaters, process burners, commercial cooking equipment, and similar applications.



Figure 1: G960 Series Multi-Function Gas Control Valve

Features and Benefits	
<input type="checkbox"/> Optional Pressure Regulator	Provides field-adjustable flow control for range-rated applications
<input type="checkbox"/> Convertible Pressure Regulator	Permits use with LP gas or natural gas
<input type="checkbox"/> Compact Size	Permits installation in space-restrictive applications

Overview

Valve Operation

The G960 is a twin solenoid on/off valve with spring-loaded seat discs that are operated by Class B solenoids with protected rectifiers to ensure quiet operation.

When the valve is energized, the solenoid plunger is pulled into the coil, overcoming the force of the close off spring and the flow medium pressure. The valve seat discs are directly fixed to the plunger stem so the valve fully opens. The Teflon® coated plunger provides maintenance-free operation under permissible temperature and pressure specifications.

Valve Configuration

The G960 Series is available as a twin solenoid model and allows independent opening of both valve seats.

Adjustment Methods

The G960 Series offers models with either top adjustment, bottom adjustment, or no regulator adjustment.

No Regulator Adjustment

The G960 has a blank plate mounted onto the bottom of the body casting for applications where regulator adjustment control is not needed or for applications where separate adjustment control is already provided.

Regulator Adjustment

Top adjustment models have a lever-acting spring pressure regulator on either the right or left hand side of the valve. Right or left hand orientation is determined by the position of the adjustment when looking into the inlet connection of the valve. The pressure regulator is adjusted from the top of the valve when the valve is in the upright position (solenoid coils on top). Bottom adjustment models have a direct-acting spring pressure regulator on the bottom of the valve. Adjustment of the regulator is made from the bottom of the valve when the valve is in the upright position (solenoid coils on top).

The regulator controls the gas pressure at the valve outlet by positioning the regulator poppet for a selected throughput flow and pressure. This is achieved by the valve outlet pressure acting on the regulator diaphragm, which balances against the preset regulator spring. Adjustment of the spring compression determines the valve outlet pressure and the throughput flow rate.

Range of Regulation

Table 1: Range of Regulation (ANSI Z21.78) for Pressure Regulator Models

Valve Model	Q _{minimum}		Q _{maximum}	
	m ³ /h	cf/h	m ³ /h	cf/h
G960B, G960E	0.566	20	3.7	130

Note: 1 m³/h = 10.67 kW (1 cf/h = 1,000 Btu/h) natural gas at 0.64 specific gravity For LP flow rates.

Dimensions

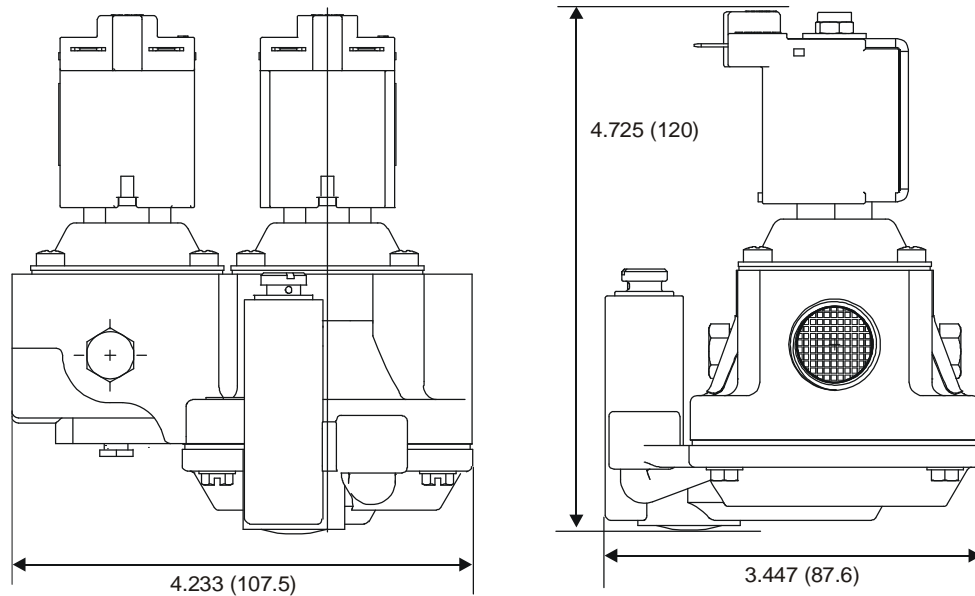
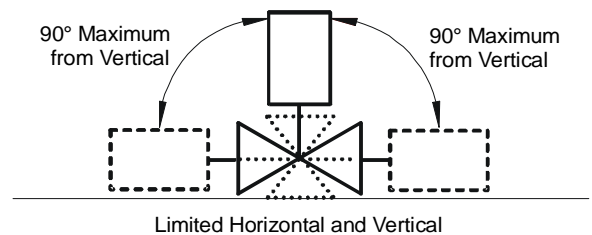

**Figure 2: Dimensions, in. (mm)
(Left-Hand Regulator Model Shown)**

Mounting

The G960 valve may be mounted on a horizontal manifold with the solenoid coils pointed up (vertical) or in any position not exceeding 90° from the vertical.

The valve may also be mounted on a vertical manifold in any position around its axis (see Figure 3). Do not install the solenoid coils upside down. Install vertically wherever possible.



**Figure 3: G960 Valve Mounting Position
Repair and Replacement**

Field repairs **must not** be made to the G960 valve. For a replacement valve, contact the original equipment manufacturer or the nearest BASO Gas Products distributor.

Ordering Information

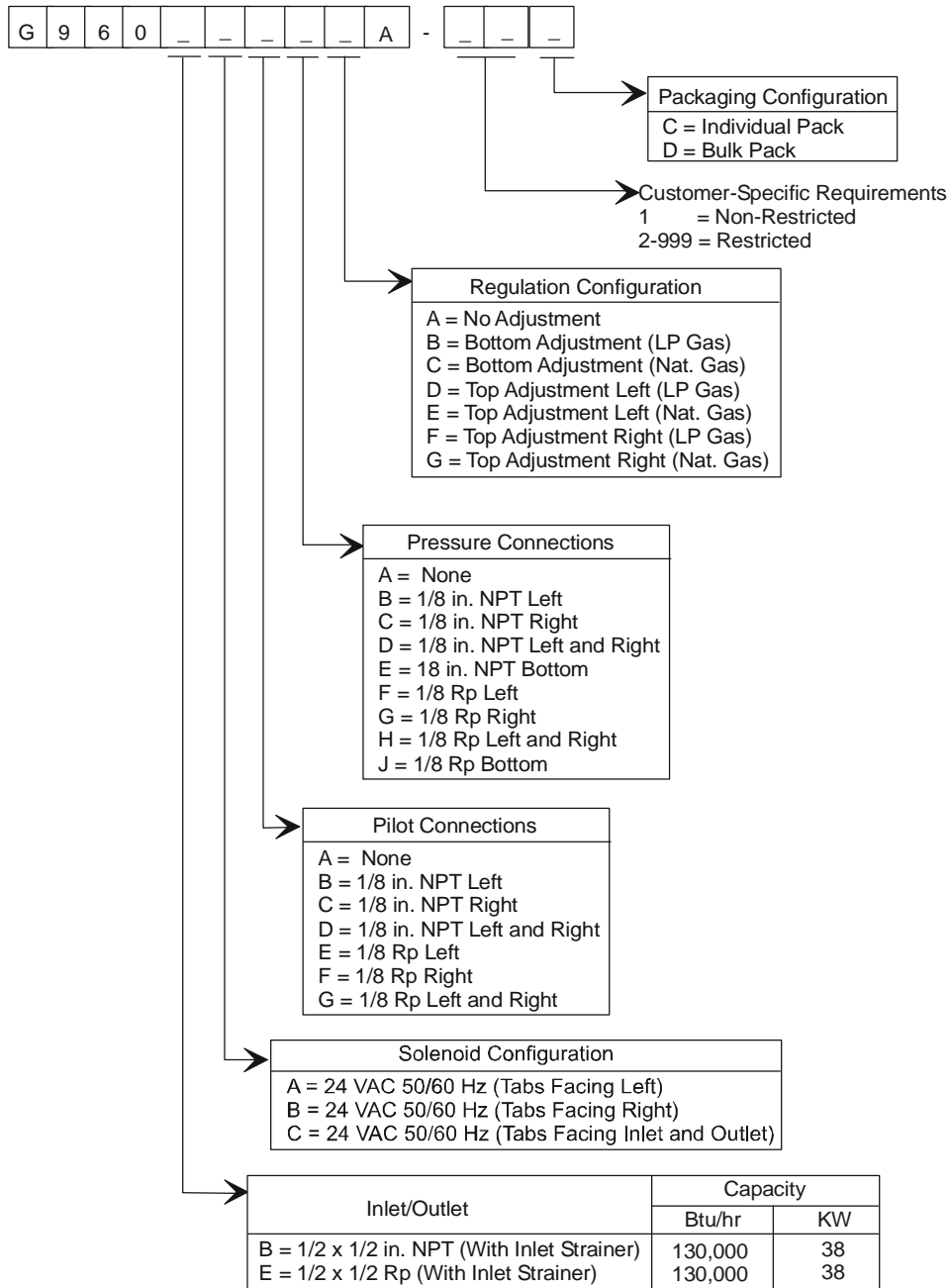

Figure 4: Valve Ordering Matrix

Performance specifications are nominal and conform to acceptable industry standards. All agency certification of BASO products is performed under dry and controlled indoor environmental conditions. Use of BASO products beyond these conditions is not recommended and may void the warranty. Product must be protected if exposed to water (dripping, spraying, rain, etc.) or other harsh environments. The original equipment manufacturer or end user is responsible for the correct application of BASO products. Consult BASO Gas Products LLC for questionable applications. BASO Gas Products LLC shall not be liable for damages or product malfunctions resulting from misapplication or misuse of its products.

Refer to the G960 Series Multi-Functional Gas Control Valve Installation Instructions (Part No. BASO-INS-G960) for necessary information on the installation, use, and servicing of this product.

Technical Data

Product	G960 Series Multi-Function Gas Control Valve		
Types of Gas	2nd (Natural Gas) and 3rd (LP Gas) Family Gases		
Maximum Operating Pressure	North America:	0.5 psi	
	Europe:	50 mbar	
	Australia:	3.45 kPa	
Maximum Differential Pressure	8 in. W.C (20 mbar / 2kPa)		
Reverse Pressure Ratings	20 in W.C. (50 mbar / 5 kPa) Class B (EN 161 and 126)		
Regulator Classification	Class C (EN 126)		
Regulator Pressure Range	Natural Gas:	3 to 6 in. W.C (7.5 to 15 mbar / 0.75 to 1.5 kPa) Top or Bottom Adjust	
	LP Gas:	8 to 12 in W.C. (20 to 30 mbar / 2.0 to 3.0 kPa) Bottom Adjust	
		6 to 12 in. W.C. (15 to 30 mbar / 1.5 to 3.0 kPa) Top Adjust	
Permissible Ambient (Surface) Temperature	-20 to 175°F (-29 to 79°C)		
Body Connections	Inlet:	1/2 in. NPT or 1/2 in. Rp	
	Outlet:	1/2 in. NPT or 1/2 in. Rp	
Valve Torsion Group	Group 2 (EN 126 and EN 161)		
Pressure Taps	1/8 in. NPT or 1/8 in. Rp Outlet Tap Bottom, Left-Hand or Right-Hand		
Pilot Connection	1/8 in. NPT or 1/8 in. Rp Left-Hand or Right-Hand		
Materials	Body:	Die-cast Aluminum	
	Diaphragms and Seals:	Nitrile Rubber	
Dirt Strainer	0.036 in. (0.9 mm) Mesh		
Operating Time Rating	100% Continuous		
Valve Timings	Closing Time:	≤1 Second	
	Opening Time:	≤1 Second	
	Dead Time:	<1 Second	
Power Ratings	24 VAC, 50/60 Hz, 9.5 VA		
Electrical Connections	2-Pin Solenoid Coil:	2 x 1/4 in. (6.35 mm) Terminals	
Accessories	Conversion Kits:	Nonregulation:	Y71AA-5
		Natural Gas to LP Gas (Top Adjust):	Y71GF-4
		Natural Gas to LP Gas (Bottom Adjust):	Y71GF-3
		LP Gas to Natural Gas (Top Adjust):	Y71QH-2
		LP Gas to Natural Gas (Bottom Adjust):	Y71QH-3
Agency Listings	CSA Certificate Number 229521-1656041 EC Type Examination Certificate Number EC-87/06/052		
Specification Standards	EN 126 and EN 161 Standards Complying with EMC Directive Standards Complying with Low Voltage Directive ANSI Standards Z21.21 and Z21.78 Canadian Standards CAN1-6.5 and 1-6.20		



BASO Gas Products LLC

1007 South 12th Street
PO Box 170
Watertown, WI 53094
1-877-227-6427 (1-877-BASOGAS)

www.baso.com
Published in U.S.A.