



H91 Series BASOTROL® Shutoff Gas Valve

Applications

The H91 Series BASOTROL valves are two-wire, electrically operated shutoff valves that automatically open and close on a demand signal from a thermostat or other controlling device. These valves can be used for gas-fired appliances with a maximum operating pressure of 0.5 psi (35 mbar).

Installation

IMPORTANT: Only qualified personnel should install or service BASO® Gas Products. These instructions are a guide for such personnel. Carefully follow all instructions in this document and all instructions for the appliance.

IMPORTANT: Make all gas installations in accordance with applicable local, national, and regional regulations.



CAUTION: Risk of Electric Shock.
Disconnect power supply before making electrical connections to avoid electric shock.



WARNING: Risk of Explosion or Fire.
Shut off the gas supply at the main manual shutoff valve before installing or servicing the H91. Failure to shut off the gas supply can result in the release of gas during installation or servicing, which can lead to an explosion or fire, and may result in severe personal injury or death.



WARNING: Risk of Explosion, Fire, or Electric Shock. Label all wires before they are disconnected when replacing or servicing the H91. Wiring errors can cause improper or dangerous operation and may result in an explosion, fire, or electric shock leading to severe personal injury or death.

IMPORTANT: Verify that the valve is installed only in applications where the specified maximum ambient (surface) temperature and maximum operating pressure does not exceed the limits in the *Technical Specifications* section.

To install the H91 Series valve:

1. Shut off power to the appliance.
2. Shut off the gas at the main manual shutoff valve.
3. Label each wire with the correct terminal designation prior to disconnection.
4. Compare the voltage on the valve with the power source voltage to ensure the correct unit is being installed. For valves with 25-volt coils, use a National Electrical Code (NEC), Class 2 transformer.
Note: The transformer must be mounted to a grounded metal enclosure.
5. Ensure that the gas flows through the valve body in the direction indicated by the "IN" and "OUT" or by the arrow on the valve body. If the valve is installed with the gas flow in the opposite direction of the arrow, leakage can occur.

IMPORTANT: Do not use a wrench on any surface other than the casting flats provided at the inlet and outlet ends of the valve body. The H91 may be damaged in the mounting process if a wrench is used on any other surface. Using a wrench incorrectly may void the warranty.

6. Mount the H91 valve on a horizontal manifold with the magnetic operator pointed up (vertical) or in a position not exceeding 90° from vertical. The valve may also be mounted on a vertical manifold in any position around its axis (Figure 1).

The H91L_, M_, or AM_ valves may be mounted on a horizontal manifold only. The magnetic operator should be in the upright position.

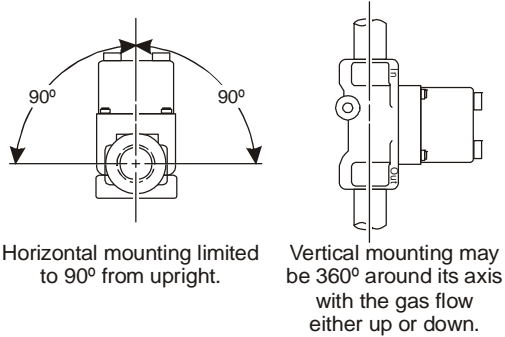

Figure 1: H91 Mounting Positions

7. Installer must be a trained, experienced, flame safeguard control technician. Threads of the pipe and nipples must be smooth and free of tears and burrs. Steam clean all piping to remove foreign substances such as cutting oil or thread chips. A sediment trap should also be installed in accordance with the National Fuel Gas Code NFPA 54 (see Figure 3). Mount the valve to the pipework, use a quality rated pipe tape, UL listed seal material rated for gasoline, propane, and other gases. If not available, a quality grade pipe dope, a light amount on the male threads, starting two threads away from the first engaging thread. If pipe dope lodges on the valve seat, it will prevent proper closure. Remove excess compound after mounting the valve to the pipework.

! WARNING: Risk of Explosion or Fire.
Verify that there are no gas leaks by testing with appropriate equipment. Never use a match or lighter to test for the presence of gas. Failure to test properly can lead to an explosion or fire and may result in severe personal injury or death.

7. Check for leakage:
 - a. Shut off the gas at the main manual shutoff valve and open the pressure connection between the manual shutoff valve and the H91 valve.
 - b. Connect air tubing with a maximum pressure of 1-1/2 times the valve's maximum operating pressure (as indicated on the valve) to the opened pressure connection.
 - c. Paint all valve body connections with a rich soap and water solution.

If bubbles occur, this is an indication of a leak. To stop a leak, tighten joints and connections. Replace the part if the leak cannot be stopped.

If bubbles do not occur, remove the air tubing and close the pressure connection.
8. Perform the *Checkout* section before leaving the installation.

Wiring

! WARNING: Risk of Shock.
Disconnect the power supply before making electrical connections to avoid electrical shock or equipment damage. Ensure that the operating voltage is identical to the information on the product identification label.

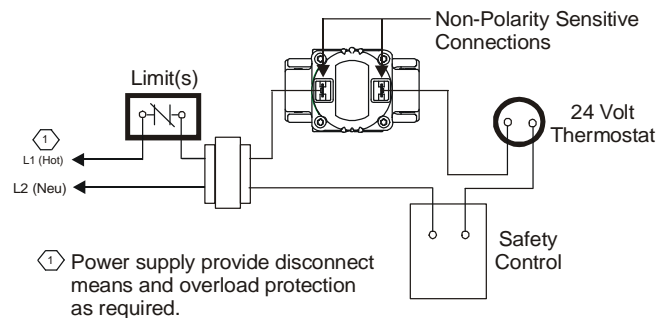

Note: Some valves may vary based on style of connections

Figure 2: Typical H91 Wiring

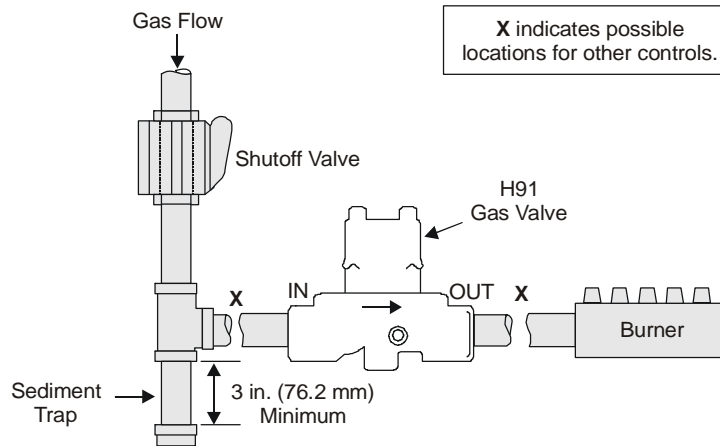

Figure 3: Typical H91 Installation

Setup and Adjustments

Checkout



WARNING: Risk of Explosion or Fire.

Follow this or an equivalent checkout procedure after installation. Before leaving the installation, verify that the gas valve functions properly and that the system has no gas leaks. Gas leaks can lead to an explosion or fire, and may result in severe personal injury or death.

Make sure all components are functioning properly by performing the following test.

1. Test all joints and connections for leaks with a rich soap and water solution. If leaks occur, see Step 8 in the *Installation* section.
2. Close the main manual shutoff valve and wait at least 5 minutes for unburned gas to escape from the appliance, and then reopen the shutoff valve.
3. Turn on the main electrical power switch and close the thermostat contacts. The appliance should operate in accordance with the manufacturer's specified sequence of operation.
4. Turn the thermostat to a low dial setting to open the contacts. All burner flames should be extinguished. Repeat Steps 3 and 4 at least three times.
5. Return the thermostat to a normal setting before leaving the installation.

Repairs and Replacement



CAUTION: Risk of Electric Shock.

Disconnect power supply before making electrical connections to avoid electric shock.



WARNING: Risk of Explosion or Fire.

Shut off the gas supply at the main manual shutoff valve before installing or servicing the H91. Failure to shut off the gas supply can result in the release of gas during installation or servicing, which can lead to an explosion or fire, and may result in severe personal injury or death.



WARNING: Risk of Explosion, Fire, or Electric Shock. Label all wires before they are disconnected when replacing or servicing the H91. Wiring errors can cause improper or dangerous operation and may result in an explosion, fire, or electric shock leading to severe personal injury or death.

Field repairs **must not** be made to the H91 valve. Any attempt to repair this assembly voids the manufacturer's warranty. For a replacement valve, contact the original equipment manufacturer or the nearest BASO Gas Products distributor.

Technical Specifications

Product	H91 Series BASOTROL Shutoff Gas Valve
Maximum Operating Pressure	0.5 psi (35 mbar)
Valve Body	Aluminum
Permissible Ambient (Surface) Temperature	CSA: -40 to 175°F (-40 to 79°C) UL: -40 to 140°F (-40 to 60°C) (except H91E_ and H91L_ -40 to 125°F [-40 to 52°C])
Available Magnetic Operator Cover Styles	Aluminum side conduit hub Aluminum top conduit hub Aluminum top outlet without conduit hub Aluminum side outlet with eyelet Steel with top conduit hub (UL Listed) Plastic with 1/4 in. (6.35 mm) male quick-connect terminals
Electrical Rating	25 VAC, 60 Hz, 0.3 A, 5 W 208/240 VAC, 60 Hz, 0.03 A, 5 W 120 VAC, 60 Hz, 0.05 A, 5 W 25 VAC, 60 Hz, 0.4 A, 7.5 W 240 VAC, 60 Hz, 0.04 A, 7 W 120 VAC, 60 Hz, 0.08 A, 7 W 240 VAC, 60 Hz, 0.03 A, 5 W 208/240 VAC, 60 Hz, 0.037 A, 6 W 12 VDC, 0.5 A
Wiring Connections	1/4 in. (6.35 mm) male quick-connect terminals or 30 in. (762 mm) lead wires (other lengths are optional)
Inlet and Outlet Pipe Size	1/8, 1/4, 3/8, 1/2, 3/4, and 1 in. NPT; 1/4, 3/8, and 1/2 in. cc; 3/8 Rp
Types of Gas	Natural, Liquefied Petroleum (LP), or LP gas-air mixtures
Packaging	Bulk pack supplied to original equipment manufacturer (individual pack optional)
Bulk Pack Quantity	40 or 80 (depending on the valve size)
Bulk Pack Weight	40 to 52 lb (18 to 24 kg)
Agency Listing	CSA Certificate Number 229521-1656058 except H91TB Australian Gas Association Certificate Number 4235, AGA Class 3 (H91A_, B_, C_, D_, E_, L_, and M_ only) UL Recognized File Number MH5939 (H91A_, B_, C_, D_, E_, J_, L_, R_, and W_ only) (except H91WS and H91RB) UL Listed File Number MH5939 (H91AA_, AB_, AC_, AD_, AM_, and AR_ only)
Specification Standards	ANSI Z21.21, CSA 6.5 AG 214 UL Standard 429

Performance specifications are nominal and conform to acceptable industry standards. All agency certification of BASO products is performed under dry and controlled indoor environmental conditions. Use of BASO products beyond these conditions is not recommended and may void the warranty. Product must be protected if exposed to water (dripping, spraying, rain, etc.) or other harsh environments. The original equipment manufacturer or end user is responsible for the correct application of BASO products. Consult BASO Gas Products LLC for questionable applications. BASO Gas Products LLC shall not be liable for damages or product malfunctions resulting from misapplication or misuse of its products.

Refer to the *H91 Series BASOTROL® Automatic Gas Valve Product Bulletin (BASO-PB-H91)* for necessary information on operating and performance specifications for this product.

1007 South 12th Street
PO Box 170
Watertown, WI 53094
1-877-227-6427 (1-877-BASOGAS)

www.baso.gas
Published in U.S.A.