



VLV49A Series Universal Replacement Gas Valve

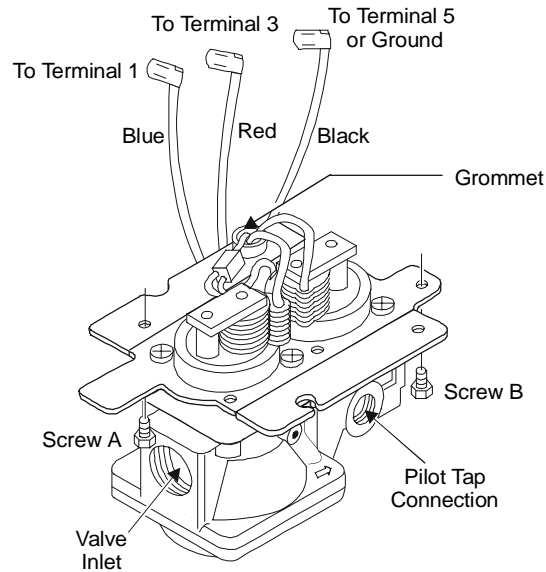

Figure 1: Universal Replacement Gas Valve

Application

The VLV49A Series Universal Replacement Gas Valve is for the replacement of the valve assembly of an electronic proven pilot spark ignition control with a valve (i.e., G60 and Q15). They are combination redundant valves, available with or without a pressure regulator.

These valves can be used on appliances burning natural gas, Liquefied Petroleum (LP) gas, manufactured gas, mixed gas or LP gas-air mixtures, including sulfur bearing gases (depending on the regulator selection) at pressures up to 35 mbar (0.5 psi).

Table 1: Specifications

Product	VLV49A Series Universal Replacement Gas Valves
Maximum Operating Pressure	35 mbar (0.5 psi)
Ambient Temperature	-40 to 80°C (-40 to 175°F)
Electrical Rating	24 VAC, 60 Hz, 0.3 ampere draw
Regulator Adjustment Range	7.5 to 15 mbar (3 to 6 in. W.C.)
Inlet Pipe Size	1/2 in. NPT
Outlet Pipe Size	3/4 in. NPT
Pilot Outlet	1/8 in.-27 NPT left and right
Wiring Connections	216 mm (8.5 in.) lead wires
Types of Gas	Natural, Liquefied Petroleum (LP), manufactured, mixed, and LP gas-air mixtures
Accessories	Conversion Kits Natural gas to LP gas: lever-acting regulator Y71GF-4 direct-acting regulator Y71GF-3
Agency Listings	None

The performance specifications are nominal and conform to acceptable industry standards. For application at conditions beyond these specifications, consult BASO Gas Products. BASO Gas Products shall not be liable for damages resulting from misapplication or misuse of its products.

Table 2: Universal Replacement Gas Valve Chart

Valve Part Number	Regulator Type
VLV49A-600R	Direct-acting regulator
VLV49A-601R	Lever-acting regulator
VLV49A-602R	No regulator

Table 3: Replacement Valve Selection Chart

Original Valve/Ignition Part Number	Replacement Valve Part Number
G60CAA-1, 3	VLV49A-602R*
G60CAG-1, 2, 3, 4, 6, 7, 8	VLV49A-602R
G60CAG-9	VLV49A-602R*
G60CBA-1, 3	VLV49A-601R*
G60CBG-1, 3, 4, 9, 10, 11, 14, 16, 17	VLV49A-601R
G60CCA-1	VLV49A-600R*
G60CCG-1	VLV49A-600R
G60CPG-1	VLV49A-601R plus Y71GF-4
G60DBG-1	VLV49A-601R
G60DCG-1, 2, 4	VLV49A-600R
G60QAG-1, 2, 3	VLV49A-602R
G60QAG-1	VLV49A-602R
G60QAK-1	VLV49A-602R
G60QBG-1, 2, 3, 4, 5, 6, 7, 8, 9	VLV49A-601R
G60QBH-1	VLV49A-601R
G60QBK-1	VLV49A-601R
G60QBK-3	VLV49A-601R
G60QBL-1	VLV49A-601R
G60QCG-1	VLV49A-600R
G60QCL-1	VLV49A-600R
G60QCJ-1	VLV49A-600R
G60QDG-1	No Replacement Available
G60QFL-1	VLV49A-602R
G60QHL-1, 2	VLV49A-600R
G60QJL-1	No Replacement Available
G60QLG-1	VLV49A-601R
G60QPL-1	VLV49A-601R plus Y71GF-4
G60QRH-1	VLV49A-601R plus Y71GF-4
G60QRL-1, 2, 3	VLV49A-601R plus Y71GF-4
G60QSL-1	VLV49A-600R plus Y71GF-3
G60QTH-1	VLV49A-601R
G60QTL-1	VLV49A-601R
G60QUL-1	VLV49A-601R
G60RAG-1	VLV49A-602R
G60RBG-1, 2	VLV49A-601R
G60RBG-3	VLV34A-648R
G60RBK-1, 2	VLV49A-601R
G60RCG-2	VLV49A-600R
G60RCJ-1	VLV49A-600R
G60RDG-1	No Replacement Available
G60RDK-1	No Replacement Available
G60RGL-1	VLV49A-601R
G60RHL-1	VLV49A-600R
Continued on next page . . .	

Original Valve/Ignition Part Number (Cont.)	Replacement Valve Part Number
G60RHP-1	VLV49A-600R
G60RPL-1	VLV49A-601R plus Y71GF-4
G60RSL-1	VLV49A-600R plus Y71GF-3
VLV34A-605	VLV49A-601R
VLV34A-608	VLV49A-602R
VLV34A-609	VLV49A-601R
VLV34A-610	VLV49A-602R
VLV34A-613	VLV49A-602R
VLV34A-614	VLV49A-601R
VLV34A-617	VLV49A-600R
VLV34A-621	VLV49A-600R
VLV34A-623	VLV49A-601R
VLV34A-624	VLV49A-602R
VLV34A-625	VLV49A-601R
VLV34A-626	VLV49A-600R
VLV34A-628	VLV49A-600R
VLV34A-633	VLV49A-601R
VLV34A-636	VLV49A-601R
VLV34A-637	VLV49A-600R
VLV34A-638	VLV49A-602R
VLV34A-639	VLV49A-601R
VLV34A-640	VLV49A-602R
VLV34A-641	VLV49A-602R
VLV34A-642	VLV49A-601R
VLV34A-643	VLV49A-600R
VLV34A-644	VLV49A-600R
VLV34A-645	VLV49A-601R
VLV34A-648	VLV34A-648R
VLV37A-602	No Replacement Available
VLV37A-603	No Replacement Available
VLV41A-600	VLV49A-602R
VLV41A-601	VLV49A-601R
VLV41A-602	VLV49A-600R
VLV41A-605	VLV49A-601R
VLV43A-600	VLV49A-601R
VLV43A-601	VLV49A-602R
VLV43A-602	VLV49A-601R
VLV43A-603	VLV49A-600R
VLV43A-604	VLV49A-600R
VLV43A-605	VLV49A-601R
VLV43A-606	VLV49A-601R
VLV43A-607	VLV49A-602R
VLV43A-608	VLV49A-601R
VLV43A-612	VLV49A-600R
Continued on next page . . .	

Original Valve/Ignition Part Number (Cont.)	Replacement Valve Part Number
VLV43A-609	VLV49A-601R
VLV43A-610	VLV49A-601R
VLV43A-615	VLV49A-601R
VLV43A-616	VLV49A-600R
VLV44A-600	No Replacement Available
VLV44A-601	No Replacement Available
VLV49A-604R	VLV49A-600R plus Y71GF-3
VLV49A-605R	VLV49A-601R plus Y71GF-4
VLV49A-606R	VLV49A-601R
G96JGA-3 (Q15HAA-1)	VLV49A-601R

* 24 VAC replacement gas valve for original 120 VAC valve. A 24 VAC transformer is required.

Note: All replacement valves come set up for use with natural gas. If used on an LP system, the appropriate Y71 conversion kit must be installed.

- Y71GF-3 Natural to LP for direct-acting regulators
- Y71GF-4 Natural to LP for lever-acting regulators

Installation

IMPORTANT: This technical bulletin is intended as a guide for authorized service personnel installing or servicing BASO Gas products. Carefully follow all instructions in this bulletin and all instructions on the appliance. Limit repairs, adjustments, and servicing to the operations listed in this bulletin or on the appliance.

 **WARNING:** **Fire or Explosion Hazard.** The system must meet all applicable codes. Improper installation may cause gas leaks, explosions, property damage, and injuries.

 **WARNING:** **Fire or Explosion Hazard.** To prevent leakage of upstream gas, shut off the gas supply at the main manual shutoff valve before installing or servicing the VLV valve.

 **CAUTION:** **Equipment Damage Hazard.** To prevent damage to the valve when mounting to the manifold, do not use a wrench on any surface other than the casting flats provided at the inlet and outlet ends of the valve body.

 **CAUTION:** **Equipment Damage Hazard.** Label all wires prior to disconnection when replacing the valve. Wiring errors can cause improper and dangerous operation. Verify proper operation after servicing.

Perform the following procedure to install the replacement VLV49A valve.

1. Turn off power to the appliance.
2. Turn off the gas at the manual shutoff valve adjacent to the appliance. (If the manual shutoff valve services more than one appliance, be sure to light the other pilots before leaving.)
3. With the gas and power to the appliance turned off, disconnect the power supply (transformer) and the thermostat lead wire at the ignition control.

4. Disconnect the sensing probe lead from Terminal 4 on the ignition control.
5. Disconnect the high voltage cable from the spark transformer.
6. Disconnect the Pilot Valve 1 and Main Valve 3 leads from the terminal board or end plug-in Heyco terminals (see Figures 2 and 3).

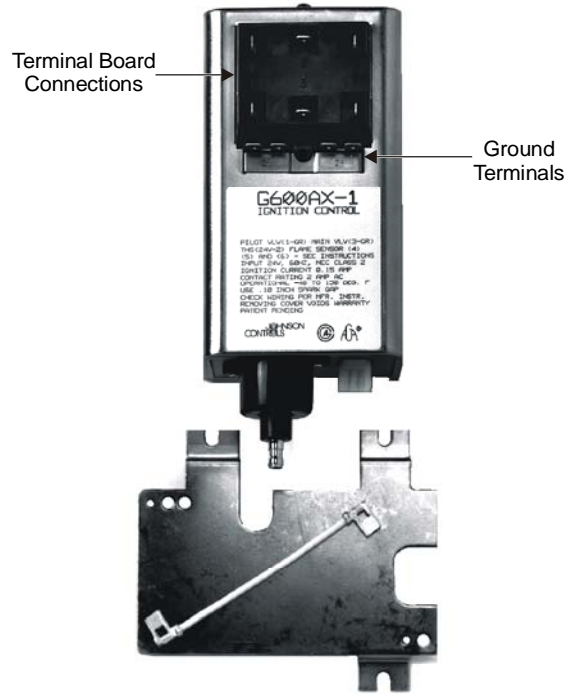

Figure 2: Terminal Board Ignition Control with Mounting Plate



Figure 3: Plug-in Heyco Ignition Control

7. Remove Screws A and B holding the ignition control assembly to the valve and plate assembly (see Figure 1). These two screws are located on the bottom surface of the ignition control assembly.
8. Remove the ignition control.
9. Disconnect the pilot burner tubing from the pilot tap connection on the gas valve (see Figure 1).
10. Verify (when looking on the inlet of the valve) that the location of the grommet and wire leads on the old valve and new replacement valve are on the same side.

If they are not on the same side, remove the grommet of the new replacement valve and insert it into the other side of the mounting plate (see Figure 4). This allows the placement of the ignition control spark transformer over the outlet of the valve instead of the inlet.

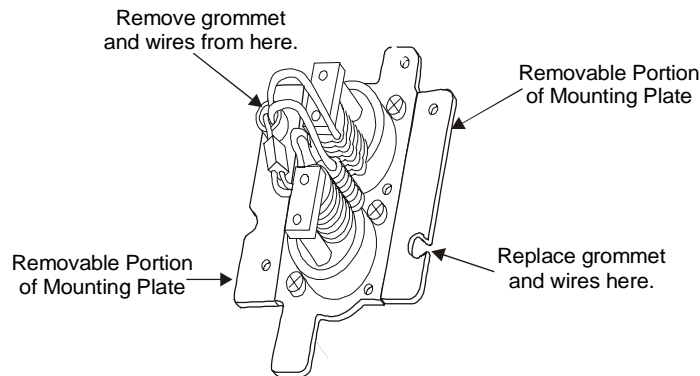

Figure 4: Grommet Locations

11. Remove the old valve from the manifold and install the new replacement valve. Ensure the gas flows through the valve body in the direction indicated by the arrow on the valve body. If the valve is installed with the gas flow opposite the arrow, leakage can occur.
A thread lubricant has been factory applied to the first two or three threads of the valve inlet and outlet to avoid galling. Use an approved pipe-joint sealing compound on male threads before assembling. Take care that excess compound does not work into the valve and get onto the valve seats. Threads of pipe and nipples must be smooth and free of tears and burrs.
12. Reconnect the pilot burner tubing at the pilot tap connection.
13. Fasten the ignition control assembly to the valve and plate assembly with the screws provided with the replacement valve.
14. Break off the portion of the plate that protrudes if it interferes with surrounding surfaces (see Figure 4).

15. Reconnect the thermostat leads, the sensing probe lead, and the high voltage cable according to the labels on the wires. **Do not connect the electrical supply at this time.**

a. On grounded versions (part numbers ending with the letters H, L, G, or J [e.g., G60QBG or G60QBJ]), connect the black lead wire to one of the ground terminals on the ignition control. Four ground spade terminals are located just below the terminal board on terminal board models (see Figure 2) or in a square arrangement on the end of the plug-in Heyco models (see Figure 3).

On ungrounded versions (part numbers ending with a K [e.g., G60QBK]), connect the black lead wire to Terminal 5 on the ignition control.

On systems using G600 ignition controls, connect the black lead wire to a ground terminal on the ignition control.

b. Connect the blue lead wire to Terminal 1 on the ignition control.

IMPORTANT: To permit verification of pilot operation, do not connect the red lead wire to any terminal at this time.

16. Check for leakage.

- a. Open the pressure connection between the manual shutoff valve and the VLV valve.
- b. Connect air tubing with a maximum pressure of 1-1/2 times the valve's maximum operating pressure (as indicated on the valve) to the opened pressure connection.
- c. Paint all valve body connections with a rich soap and water solution.

If bubbles occur, this is an indication of a leak. To stop a leak, tighten joints and connections. Replace the part if the leak cannot be stopped.

If bubbles do not occur, remove the air tubing and close the pressure connection.

17. After installation of the replacement valve is complete, **except for the attachment of the red lead wire**, turn on the gas at the manual shutoff valve.
 - a. Reconnect the power supply lead wire to the ignition control and turn the power On.
 - b. Set the thermostat to the highest setting. The pilot valve will open, spark will be energized, and the pilot will light.
 - c. Test for gas leaks in the pilot line with a soap solution.
 - d. After the check is complete, turn off the power and **connect the red lead wire to Terminal 3** on the ignition control.
18. Turn on the power and set the thermostat to the desired setting.

Regulator Adjustment

IMPORTANT: All adjustments must be made in conjunction with the gas appliance and in accordance with the appliance manufacturer's instruction. Only authorized personnel should make adjustments.



WARNING: Explosion Hazard. The minimum flow rate of the valve must not be adjusted below the minimum safe working rate of the appliance.

The pressure regulator is adjustable and has been factory set. If a different setting is desired, follow these instructions.

1. Shut off all gas to the appliance.
2. Turn the thermostat to the lowest setting or Off position.
3. Remove the pressure tap plug at the valve outlet or in the manifold pipe downstream of the valve.
4. Install a manometer or pressure gauge suitable for measuring the desired orifice pressure.
5. Remove the seal screw at the end of the regulator stack.
6. Turn the gas on and place the thermostat at the highest setting to cycle the ignition system.
7. Allow the system to stabilize. Adjust the screw in the regulator stack to the desired reading on the manometer. (Turn clockwise to increase the outlet pressure and counterclockwise to reduce the outlet pressure.)
8. Reinstall the seal screw, which incorporates the proper size hole for venting to the atmosphere. (It may be necessary to cycle the valve several times to verify the desired outlet pressure.)
9. Turn off the gas supply and place the thermostat at the lowest setting.
10. Remove the pressure manometer and reinstall the pressure tap plug.
11. Turn the gas on and set the thermostat to the desired setting.
12. Check for leaks at the pressure tap plug with a soap solution before leaving the site.

Checkout Procedure



WARNING: Fire or Explosion Hazard. Avoid personal injury or property damage by making sure the valve functions properly and there are no gas leaks. Follow this checkout procedure before leaving the installation.

Make sure all components are functioning properly by performing the following test:

1. Test for leaks on all pipe joints and connections upstream of the gas valve with a soap solution.
2. Turn the thermostat to a low setting.
3. Turn on the gas and purge the gas lines of all air.
4. Turn the thermostat to a high setting. The appliance should operate in accordance with the manufacturer's specified sequence of operation.
5. Test for leaks on all pipe joints and connections downstream of the gas valve with a soap solution.
6. Turn the thermostat down for at least 30 seconds and then back up again. Verify successful ignition at least three times before leaving the installation.

Repairs and Replacement

The VLV49A replacement valves are not field repairable. **Do not** attempt field repairs. For a replacement valve, contact the nearest BASO Gas Products distributor.



BASO Gas Products LLC

1007 South 12th Street
PO Box 170
Watertown, WI 53094
1-877-227-6427 (1-877-BASOGAS)

www.baso.com
Printed in U.S.A.