



G96 Series BASOTROL® Dual Operator Valve

Applications

The G96 valves are combination, dual operator, automatic valves available with or without a pressure regulator. Typical applications include central heating units, unit heaters, rooftop units, make up air heaters, and similar applications.

Installation

IMPORTANT: Only qualified personnel should install or service BASO Gas Products® products. These instructions are a guide for such personnel. Carefully follow all instructions in this document and all instructions for the appliance.

IMPORTANT: Make all gas installations in accordance with applicable local, national, and regional regulations.



CAUTION: Risk of Electric Shock.

Disconnect power supply before making electrical connections to avoid electric shock.



WARNING: Risk of Explosion or Fire.

Shut off the gas supply at the main manual shutoff valve before installing or servicing the G96. Failure to shut off the gas supply can result in the release of gas during installation or servicing, which can lead to an explosion or fire, and may result in severe personal injury or death.



WARNING: Risk of Explosion, Fire, or Electric Shock. Label all wires before they are disconnected when replacing or servicing the G96. Wiring errors can cause improper or dangerous operation and may result in an explosion, fire, or electric shock leading to severe personal injury or death.

IMPORTANT: Verify that the valve is installed only in applications where the specified maximum ambient (surface) temperature and maximum operating pressures do not exceed the limits in the *Technical Specifications* section.

To install the G96 valve:

1. Shut off power to the appliance.
2. Shut off the gas at the main manual shutoff valve.
3. Label each wire with the correct terminal designation prior to disconnection.
4. Compare the voltage on the valve with the power source voltage to ensure the correct unit is being installed. For valves with 25-volt coils, use a National Electrical Code (NEC), Class 2 transformer.
Note: The transformer must be mounted to a grounded metal enclosure.
5. Ensure that the gas flows through the valve body in the direction indicated by the arrow on the valve body. If the valve is installed with the gas flow in the opposite direction of the arrow, leakage can occur.

IMPORTANT: Do not use a wrench on any surface other than the casting flats provided at the inlet and outlet ends of the valve body. The G96 may be damaged in the mounting process if a wrench is used on any other surface. Using a wrench incorrectly may void the warranty.

- Mount the G96 on a horizontal manifold with the magnetic operator pointed up (vertical) or in a position not exceeding 90° from vertical. The valve may also be mounted on a vertical manifold in any position around its axis (see Figure 1).

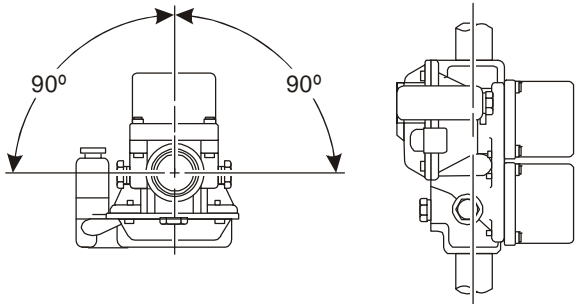

Horizontal mounting limited to 90° from upright.

Vertical mounting may be 360° around its axis with the gas flow either up or down but always in the direction of the arrow.

Figure 1: G96 Mounting Positions

- Mount the valve to the pipework. Use an approved pipe joint sealing compound on the male threads before assembly. Remove excess compound after mounting the valve to the pipework. Threads of the pipe and nipples must be smooth and free of tears and burrs. Steam clean all piping to remove foreign substances such as cutting oil or thread chips. A sediment trap should also be installed in accordance with the National Fuel Gas Code (ANSI Z223.1). See Figure 2.

- Attach the pilot gas line to the pilot burner fitting and to the pilot gas outlet of the valve (if used).



WARNING: Risk of Explosion or Fire.

Verify that there are no gas leaks by testing with appropriate equipment. Never use a match or lighter to test for the presence of gas. Failure to test properly can lead to an explosion or fire and may result in severe personal injury or death.

- Check for leakage.
 - Shut off the gas at the main manual shutoff valve and open the pressure connection between the manual shutoff valve and the G96 valve.
 - Connect air tubing with a maximum pressure of 1-1/2 times the valve's maximum operating pressure (as indicated on the valve) to the opened pressure connection.
 - Paint all valve body connections with a rich soap and water solution. If bubbles occur, this indicates a leak. To stop a leak, tighten joints and connections. Replace the part if the leak cannot be stopped. If bubbles do not occur, remove the air tubing and close the pressure connection.
- Perform the *Checkout* section before leaving the installation.

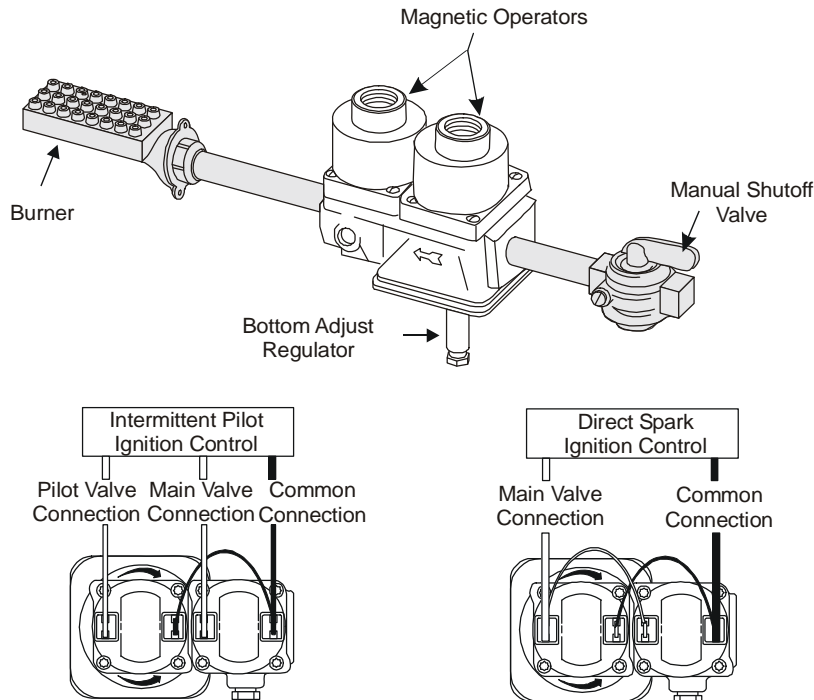

Figure 2: Typical G96 Installation and Wiring

Setup and Adjustments

Checkout Procedure



WARNING: Risk of Explosion or Fire.

Follow this or an equivalent checkout procedure after installation. Before leaving the installation, verify that the gas valve functions properly and that the system has no gas leaks. Gas leaks can lead to an explosion or fire, and may result in severe personal injury or death.

Make sure all components are functioning properly by performing the following test:

1. Test all joints and connections for leaks with a soap solution.
2. Close the main upstream shutoff valve and wait at least 5 minutes for unburned gas to escape from the appliance, and then reopen the shutoff valve.
3. Turn on the main electrical power switch and close the thermostat contacts. The appliance should operate in accordance with the manufacturer's specified sequence of operation.
4. Turn the thermostat to a low dial setting to open the contacts. All burner flames should be extinguished. Repeat Steps 3 and 4 at least three times.
5. Return the thermostat to a normal setting before leaving the installation.

Regulator Adjustment



WARNING: Risk of Explosion or Fire.

Do not adjust the minimum flow rate of the valve below the minimum safe working rate of the appliance. This may cause gas leaks, which can lead to an explosion or fire, and may result in severe personal injury or death.

IMPORTANT: Refer to and follow any specific instructions issued by the appliance manufacturer with regards to servicing their equipment.

The pressure regulator is adjustable and has been set to a specific customer requirement. If a different setting is desired, follow these instructions.

1. Shut off all gas to the appliance.
2. Turn the thermostat to the lowest setting or Off position.
3. Remove the pressure tap plug at the valve outlet or in the manifold pipe downstream of the valve.
4. Install a manometer or pressure gauge suitable for measuring the desired orifice pressure.
5. Remove the seal screw at the end of the regulator stack.
6. Turn the gas on and place the thermostat at the highest setting to cycle the system.
7. Allow the system to stabilize. Adjust the screw in the regulator stack to the desired reading on the manometer. (Turn clockwise to increase the outlet pressure and counterclockwise to reduce the outlet pressure.)
8. Reinstall the seal screw, which incorporates the proper size hole for venting to the atmosphere. (It may be necessary to cycle the valve several times to verify the desired outlet pressure.)
9. Turn off the gas supply and place the thermostat at the lowest setting.
10. Remove the pressure manometer and reinstall the pressure tap plug.
11. Turn the gas on and set the thermostat to the desired setting.
12. Check for leaks at the pressure tap plug with a soap solution before leaving the site.

Repairs and Replacement



CAUTION: Risk of Electric Shock.

Disconnect power supply before making electrical connections to avoid electric shock.

Field repairs **must not** be made to the G96 valve. Any attempt to repair this assembly voids the manufacturer's warranty. For a replacement valve or valve accessories, contact the original equipment manufacturer or the nearest BASO Gas Products distributor.



WARNING: Risk of Explosion or Fire.

Shut off the gas supply at the main manual shutoff valve before installing or servicing the G96. Failure to shut off the gas supply can result in the release of gas during installation or servicing, which can lead to an explosion or fire, and may result in severe personal injury or death.



WARNING: Risk of Explosion or Fire, or Electric Shock. Label all wires before they are disconnected when replacing or servicing the G96. Wiring errors can cause improper or dangerous operation and may result in an explosion, fire, or electric shock leading to severe personal injury or death.

Technical Specifications

Product	G96 Series BASOTROL Dual Operator Valve			
Maximum Operating Pressure	0.5 psi (35 mbar)			
Permissible Ambient (Surface) Temperature	-20 to 175°F (-29 to 79°C) nitrile diaphragm -40 to 175°F (-40 to 79°C) silicone diaphragm			
Available Magnetic Operator Cover Styles	Aluminum side conduit hub Aluminum top conduit hub Aluminum top without conduit hub Aluminum side outlet with eyelet Steel top conduit hub Plastic with 1/4 in. (6.35 mm) male quick-connect terminals			
Electrical Rating	25 VAC, 60 Hz, 0.3 ampere draw for each operator 120 VAC, 60 Hz, 0.05 ampere draw for each operator 240 VAC, 60 Hz, 0.03 ampere draw for each operator			
Regulator Adjustment Range	Bottom Adjust Regulators:	3 to 6 in. W.C. (7.5 to 15 mbar) 8 to 12 in. W.C. (20 to 30 mbar)		
	Top Adjust Regulators:	3 to 6 in. W.C. (7.5 to 15 mbar) 6 to 12 in. W.C. (15 to 30 mbar)		
Inlet Pipe Size	1/2 in. NPT			
Outlet Pipe Size	1/2 or 3/4 in. NPT			
Pilot Outlet	1/8 in.-27 NPT, 1/4 in. cc also available			
Wiring Connections	1/4 in. (6.35 mm) male quick-connect or 30 in. (762 mm) lead wires (other lengths are optional)			
Types of Gas	Natural or Liquefied Petroleum (LP)			
Accessories	Conversion Kits	Natural Gas to LP Gas:	Top Adjust Regulator Bottom Adjust Regulator	Y71GF-4 Y71GF-3
		LP Gas to Natural Gas:	Top Adjust Regulator Bottom Adjust Regulator	Y71QH-2 Y71QH-3
		Non-Regulation:	Top or Bottom Adjust Regulator	Y71AA-5
Packaging	Bulk pack supplied to original equipment manufacturer (individual pack optional).			
Bulk Pack Quantity	32 per carton (G96HGA and G96JGA bulk pack quantity is 20 per carton)			
Bulk Pack Weight	49 lb (22 kg) per carton (G96HGA and G96JGA weight is 20 lb [14 kg] per carton)			
Agency Listings	CSA Certificate Number 229521-1656041 (G96A_ , H_ , and J_ _ only) Australian Gas Association Certificate Number 3495 (G96HGA and SHA only) AGA Regulation Type B, Class 2, Grade B; Automatic Class 3			
Specifications Standards	ANSI Z21.21, CSA 6.5 ANSI Z21.78, CSA 6.20 AG 209 AG 214			

Performance specifications are nominal and conform to acceptable industry standards. All agency certification of BASO products is performed under dry and controlled indoor environmental conditions. Use of BASO products beyond these conditions is not recommended and may void the warranty. Product must be protected if exposed to water (dripping, spraying, rain, etc.) or other harsh environments. The original equipment manufacturer or end user is responsible for the correct application of BASO products. Consult BASO Gas Products LLC for questionable applications. BASO Gas Products LLC shall not be liable for damages or product malfunctions resulting from misapplication or misuse of its products.

Refer to the *G96 Series BASOTROL Dual Operator Valve Product Bulletin (BASO-PB-G96)* for necessary information on operating and performance specifications of this product.

1007 South 12th Street
PO Box 170
Watertown, WI 53094
1-877-227-6427 (1-877-BASOGAS)

www.baso.com
Printed in U.S.A.