



GM-7000 Series CE Approved Gas Control Valve

The GM-7000 Series multi-function gas control valve works in conjunction with an electronic sequence control unit to provide fully automatic control for residential and light commercial heating, cooking, drying, and other light commercial applications.

Typical applications include freestanding and wall hung boilers for residential hydronic heating, commercial cooking appliances, and commercial tumbler dryers.



Figure 1: GM-7000 Multi-Function Gas Control Valve

Features and Benefits	
<input type="checkbox"/> Optional Pressure Regulator	Provides field adjustable flow control for range-rated applications
<input type="checkbox"/> Convertible Pressure Regulator	Permits use with Liquid Petroleum (LP) gas or natural gas
<input type="checkbox"/> Compact Size	Permits installation in space-restrictive applications
<input type="checkbox"/> CE Compliant	Broadens applications to include markets in Europe

Overview

Valve Operation

The GM-7000 is an on/off valve with spring-loaded seat discs that are operated by solenoids with protected rectifiers to ensure quiet operation.

When the valve is energized, the solenoid plunger is pulled into the coil, overcoming the force of the closeoff spring and the flow medium pressure. The valve seat discs are directly fixed to the plunger stem so the valve fully opens.

The Teflon® coated plunger provides maintenance-free operation under permissible temperature and pressure specifications.

Valve Types

The GM-7000 valve is available with 25 VAC solenoids and 1/2-inch body thread connections.

Adjustment Methods

The GM-7000 Series offers direct-acting regulator control.

No Regulator

The GM-7_1_ model has a blank plate mounted onto the bottom of the body casting for applications where adjustment control is not needed or for applications where separate adjustment control is already provided.

Regulator Adjustment

The regulator controls the gas pressure at the valve outlet by positioning the regulator poppet for selected throughput flow and pressure. Regulator pressure is achieved by the valve outlet pressure acting on the regulator diaphragm, which balances against the preset regulator spring. Adjustment of the spring compression determines the valve outlet pressure and the throughput flow rate.

The GM-7532 model has a direct-acting pressure regulator. The direct-acting regulator operates by means of the regulator spring acting directly onto the regulator diaphragm. The direct-acting regulator is adjusted from the underside of the valve.

Table 1: Range of Regulation (ANSI Z21.78) for Pressure Regulator Models

Valve Model	Q _{minimum}		Q _{maximum}	
	m ³ /h	cf/h	m ³ /h	cf/h
GM7000	0.566	20	2.83	100

Note: 1 m³/h – 10.67 kW (1 cf/h = 1,000 Btu/h) natural gas at 0.64 specific gravity.

Range of Regulation

Pressure Regulator Model GM-7_3_

The GM-7_3_ model has an adjustable direct-acting pressure regulator. The direct-acting pressure regulator has the following pressure range:

- Natural gas 7.5 to 12 mbar (3 to 5 in. W.C.)
- Liquid Petroleum (LP) gas 22.5 to 30 mbar (9 to 12 in. W.C.)

Mounting

The GM-7000 valve may be mounted on a horizontal manifold with the magnetic operators (solenoid coils) pointed up (vertical) or in any position not exceeding 90° from the vertical (Figure 2)

The valve also may be mounted on a vertical manifold in any position around its axis. Do not install the solenoid actuator upside down. Install the valve on a horizontal manifold wherever possible.

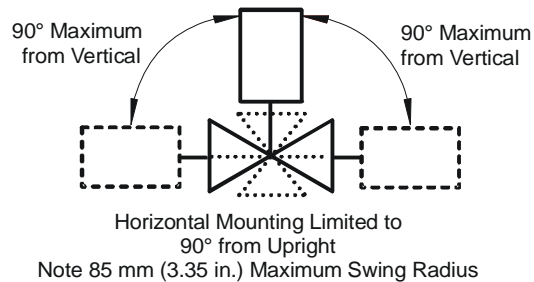

Figure 2: GM-7000 Mounting Positions

Accessories

Table 2: Accessories

Description	Part Number
Conversion Kit for Non-Regulation	BG-70- CBP* GM-70-CBP**
Conversion Kit for LP Regulation	GM-70-CLP
Conversion Kit for Natural Gas Regulation	GM-70-CNG

*use on valves with date codes after W1025

**use on valves with date codes before W1025

Repairs and Replacement

Table 3: Replacement Solenoid Coil

Part Number	Description
RSDA95A-25	25 VAC; 50/60 Hz; 3-tab 10.5 VA Coil
RSDA95A-25A	25 VAC; 50/60 Hz; 2-tab 10.5 VA Coil

Do not make field repairs except for the replacement of the solenoid coils.

For a replacement coil or gas valve, contact the original equipment manufacturer or the nearest BASO Gas Products® distributor.

Dimensions

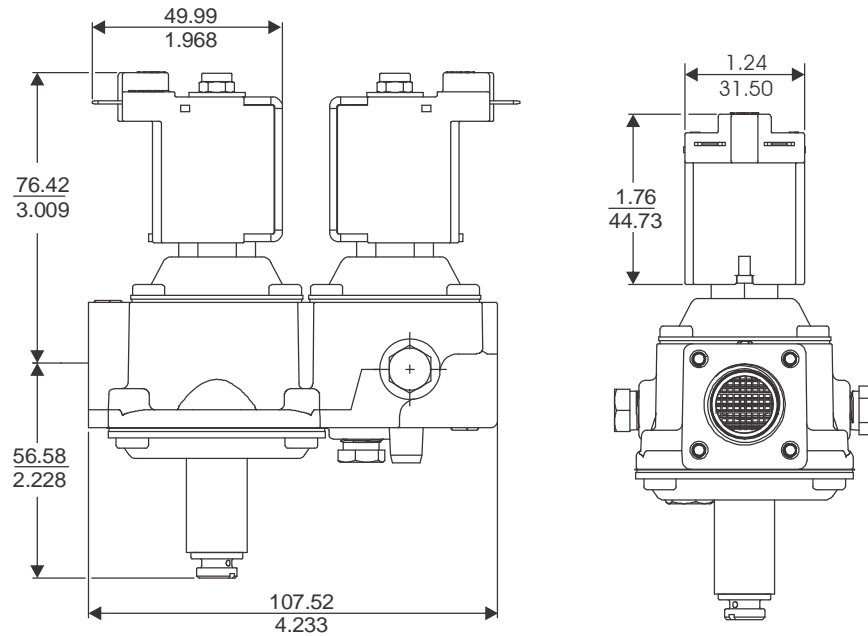

Figure 3: Valve with Direct-Acting Pressure Regulator and 2-pin, 24 VAC, 9.5 VA Coils, mm (in.)

Ordering Information

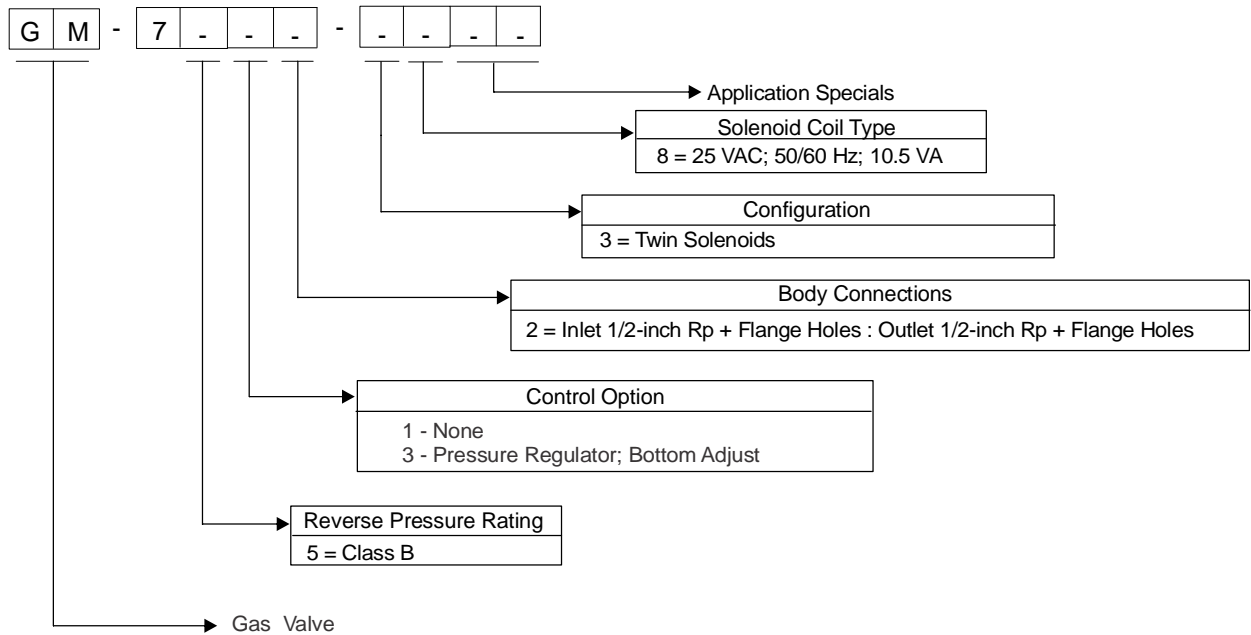

Figure 4: Valve Ordering Matrix

Technical Specifications

Product	GM-7000 Series CE Approved Gas Control Valve	
Types of Gas	Natural, Liquefied Petroleum (LP), and LP gas-air mixtures	
Maximum Operating Pressure	North America:	1/2 psi
	Europe:	50 mbar; Class B (EN 126 and 161)
Maximum Differential Pressure	20 mbar (8 in. W.C.)	
Reverse Pressure Rating	50 mbar (20 in. W. C.) Class B (EN 126 and 161)	
Regulator Classification	Class C (EN 126)	
Direct-Acting Regulator Pressure Range	Natural Gas:	7.5 to 12 mbar (3 to 5 in. W.C.)
	LP Gas:	22.5 to 30 mbar (9 to 12 in. W.C.)
Permissible Ambient (Surface) Temperature	0 to 70°C (32 to 158°F)	
Body Connections	1/2 NPT, 1/2 BSPP (Thread ISO 7-Rp) with Flange Connection Holes (M4 x 0.7 mm pitch x 6 mm deep)	
Valve Torsion Group	Group 2 (EN 126 and EN 161)	
Pressure Taps	M5 x 0.8 Thread	
Pilot Connection	1/4 in. Blank Plug	
Materials	Body:	Die-Cast Aluminum
	Diaphragms and Seals:	Nitrile Rubber
Dirt Strainer	0.9 mm (0.036 in.) mesh	
Operating Time Rating	100% Continuous	
Valve Timings	Closing Time:	≤ 1 Second
	Opening Time:	≤ 1 Second
	Dead Time:	< 1 Second
Power Rating	10.5 VA per Coil	
Electrical Connection	2-Tab Solenoid Coil:	2 x 6.35 mm (1/4 in.) Tabs
	3-Tab Solenoid coil:	2 x 6.35 mm (1/4 in.) Tabs + 6.35 mm (1/4 in.) Earth Ground Tab
Agency Listings	CSA Certificate Number 229521-1656114 EC Certificate Number EC-86/11/041 Australian Gas Pending	
Specification Standards	EN 126 and EN 161 Standards Complying with the EMC Directive Standards Complying with the Low Voltage Directive Canadian Standard CSA 6.5 and 6.20 ANSI Standards Z21.21 and Z21.78	

Performance specifications are nominal and conform to acceptable industry standards. All agency certification of BASO products is performed under dry and controlled indoor environmental conditions. Use of BASO products beyond these conditions is not recommended and may void the warranty. Product must be protected if exposed to water (dripping, spraying, rain, etc.) or other harsh environments. The original equipment manufacturer or end user is responsible for the correct application of BASO products. Consult BASO Gas Products LLC for questionable applications. BASO Gas Products LLC shall not be liable for damages or product malfunctions resulting from misapplication or misuse of its products.

Refer to the *GM-7000 Series CE Approved Gas Control Valve Installation Instructions (Part No. BASO-INS-GM7000)* for necessary information on the installation, use, and servicing of this product.



BASO Gas Products LLC

PO Box 170

Watertown, WI 53094

1-877-227-6427 (1-877-BASOGAS)

www.baso.com

Published in U.S.A.