



BASO Gas Products LLC

BG1600M Intermittent Pilot Ignition Control

Application

The BG1600M Intermittent Pilot Ignition Control is a safety control designed for indirect burner ignition and supervision, for use with all gases and applicable to gas-fired appliances.

The BG1600M is a microprocessor based ignition control. The microprocessor provides reliable software control of all timings and operates a diagnostic Light-Emitting Diode (LED). It provides ignition sequence, flame monitoring, and safety shutoff for intermittent pilot boilers, furnaces and other heating appliances. For a complete listing of specifications, refer to the *Technical Specifications* section.

Installation

IMPORTANT: Only qualified personnel should install or service BASO Gas Products®. These instructions are a guide for such personnel. Carefully follow all instructions for the appliance.

IMPORTANT: Make all gas installations in accordance with applicable local, national, and regional regulations.

 **WARNING: Risk of Explosion or Fire.**
Do not install the control in an area that is exposed to water (for example, dripping, spraying, rain). Do not use the control if it has been exposed to water. Exposure to water may cause malfunction and can lead to an explosion or fire and may result in severe personal injury or death.

IMPORTANT: This control is approved for use with noise suppression (resistive) spark wires. If the application has copper wire, it must be replaced.

Instructions for installing the pilot burner/igniter-sensor are typically provided by the appliance manufacturer. It is important to follow those instructions. If such information is not included, refer to the *Mounting* section.

Mounting

 **CAUTION: Risk of Electric Shock.**
Disconnect power supply before making electrical connections to avoid electric shock.

 **WARNING: Risk of Explosion or Fire.**
Shut off the gas supply at the main manual shutoff valve before installing or servicing the control. Failure to shut off the gas supply can result in the release of gas during installation or servicing, which can lead to an explosion or fire, and may result in severe personal injury or death.

IMPORTANT: Do not mount the control where it can be exposed to direct infrared radiation from the main burner or to temperatures in excess of the maximum product temperature rating.

Location Considerations

Choose a location that provides the shortest, direct cable route to the spark electrode, pilot burner/igniter-sensor assembly. Easy access to the terminals is desired for wiring and servicing. The control may be mounted in any position. Mount the control on a grounded metal surface with #6 sheet metal or machine screws through the mounting holes provided in the enclosure.

The pilot burner/igniter-sensor must be securely mounted to the main burner to ensure that the pilot burner flame remains properly positioned with respect to the main burner flame. The pilot burner must be located such that the flame receives an ample supply of air, free from the products of combustion. The flame must not be exposed to draft conditions, the full force of main burner ignition, or falling scale, which could otherwise impede ignition of main burner flame.

Securely mount the pilot burner/igniter-sensor to the main burner with metal screws at a distance approximately 3/8 in. (9.52 mm) above and 1/4 in. (6.35 mm) away from the center of the nearest main burner port. Ensure that the main burner flames do not impinge on any part of the pilot burner.

Wiring



WARNING: Risk of Explosion or Fire.

Locate all safety, limit, and operating controls in series with the thermostat terminal (TH) on the ignition control. Improper installation may cause gas leaks, which can lead to an explosion or fire and may result in severe personal injury or death.

Refer to Figure 1 through Figure 4 for wiring diagrams. All wiring should be in accordance with the National Electrical Code (NEC) and all other local codes and regulations.

Check the voltage rating marked on the control and make sure it is suited to the application. Use a Class 2 transformer capable of providing 24 VAC under maximum load, including valves. A transformer having excessive primary impedance due to poor coupling affects the ignition potential.

The high-voltage spark transformer cable is noise suppression (resistive) type rated for at least 15Kv and must not be in continuous contact with a metal surface. Use standoff insulators. Ensure that the flame sensor wire and high voltage spark transformer cable are separated from one another by a minimum of 1/4 in. (6.35 mm) and are not wrapped around any pipe, other wiring, or accessories.

The control is supplied with a jumper wire between Sense and Internal terminals and is ready for internal (one rod) flame sense. With the jumper in, flame is sensed through the high voltage spark wire. The jumper must be removed for external (two rod) flame sense and the sense electrode wired to the Sense terminal.

Note: A shorting plug that jumpers pins 2 and 3 of the damper connector is supplied with the control. The shorting plug must be used if a vent damper is not used. When a vent damper has been connected and power turned on, an internal fuse in the control will blow and the control will only operate with a vent damper connected. Now you cannot disconnect the vent damper plug and put back the shorting plug. The ignition control will not work.



WARNING: Risk of Electric Shock.

Before applying power to the control, connect the high voltage cable to the spark transformer terminal and spark electrode (pilot burner assembly). Verify the ground wire is attached to the pilot burner and the control ground terminal strip. Failure to follow this procedure can cause electric shock and may result in severe personal injury or death.

The BG1600M replaces existing intermittent pilot ignition controls with the following specifications:

- flame detection using flame rectification technology (ability of a flame to conduct and rectify current)
- Single rod (local sense) or dual rod (remote sense) flame sensing
- 100% shutoff/lockout with none, 5 or 60 minutes continuous retry
- trial times of infinite, 5, 10, 15, 20, 25, 30, 60 or 90 seconds
- prepurge period of 0, 10, 15, 30 or 45 seconds
- main burner 400,000 Btu/hr maximum
- pilot burners with flow rates of 1,500 Btu/hr or less
- with or without automatic vent damper
- must be used with redundant gas valves and not subjected to temperatures below -40°F (-40°C) or above 170°F (77°C)

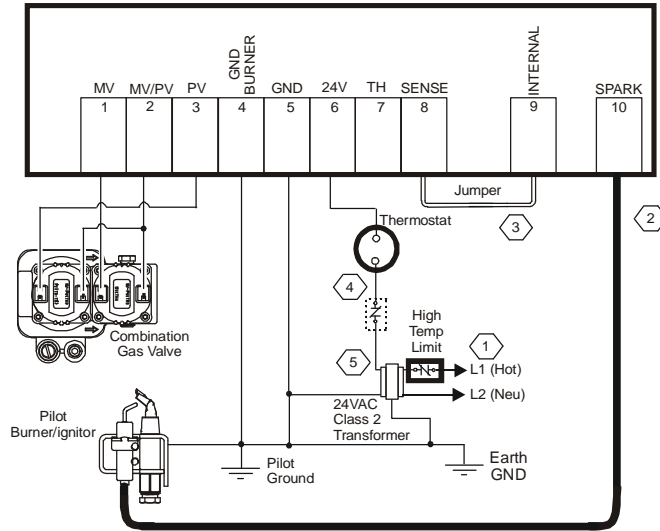

- ① Power Supply. Provides disconnect means and overload protection as required.
- ② Maximum cable length 48 inches (1,220 mm). (Resistive wire recommended.)
- ③ For single rod application, leave jumper wire in if supplied.
- ④ Alternate location for limit controller.
- ⑤ Controls in 24V circuit must not be in ground leg to transformer.

Figure 1: Wiring for 1 Rod Flame Sense without Vent Damper

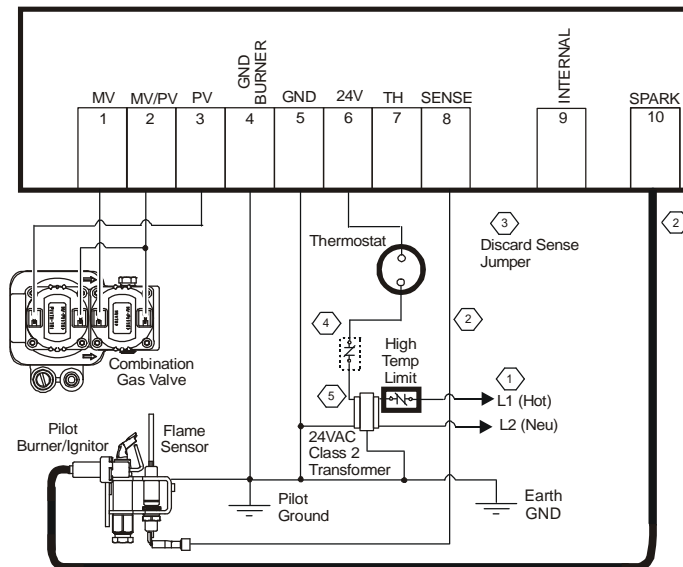

- ① Power Supply. Provides disconnect means and overload protection as required.
- ② Maximum cable length 48 inches (1,220 mm). (Resistive wire recommended.)
- ③ For two rod application, if jumper wire is supplied, remove jumper wire before installation.
- ④ Alternate location for limit controller.
- ⑤ Controls in 24V circuit must not be in ground leg to transformer.

Figure 2: Wiring for 2 Rod Flame Sense without Vent Damper

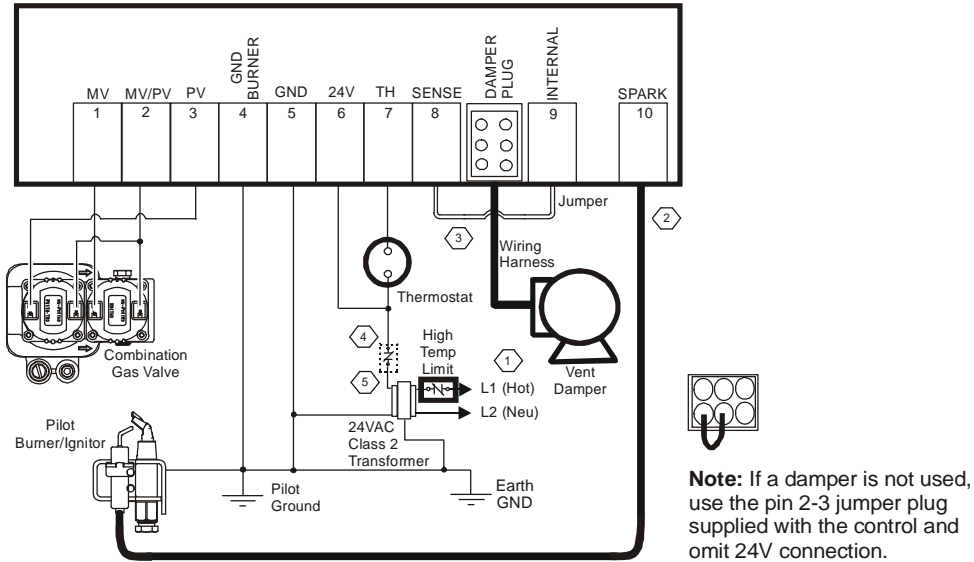

- ① Power Supply. Provides disconnect means and overload protection as required.
- ② Maximum cable length 48 inches (1,220 mm). (Resistive wire recommended.)
- ③ For single rod application, leave jumper wire in if supplied.
- ④ Alternate location for limit controller.
- ⑤ Controls in 24V circuit must not be in ground leg to transformer.

Figure 3: Wiring for 1 Rod Flame Sense with Vent Damper

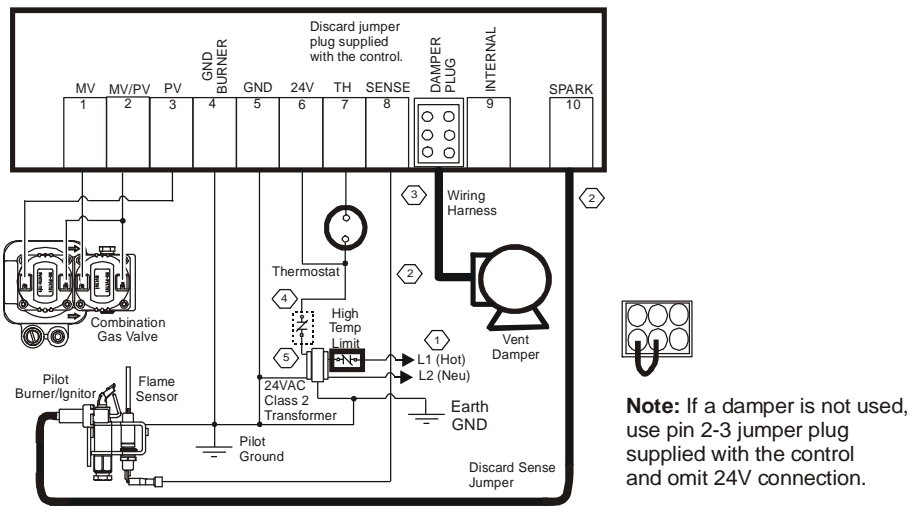

- ① Power Supply. Provides disconnect means and overload protection as required.
- ② Maximum cable length 48 inches (1,220 mm). (Resistive wire recommended.)
- ③ For two rod applications, if jumper wire is supplied, remove jumper wire before installation.
- ④ Alternate location for limit controller.
- ⑤ Controls in 24V circuit must not be in ground leg to transformer.

Figure 4: Wiring for 2 Rod Flame Sense with Vent Damper

Setup and Adjustments

Checkout



WARNING: Risk of Explosion or Fire.

Verify that there are no gas leaks by testing with appropriate equipment. Never use a match or lighter to test for the presence of gas. Failure to test properly can lead to an explosion or fire and may result in severe personal injury or death.

Make sure all components function properly by performing the following test.

1. Before starting the appliance, perform a safety inspection of piping, burners and venting. Check for water leaks, etc. Check all wiring for proper connections. Be sure the system is properly grounded, including ground connection to the pilot burner.
2. With the gas and thermostat off, turn on power to the appliance.
3. Turn the thermostat to a high setting and verify that the control goes through the operating sequence to a shutoff condition.
Note: The burner does not light because the gas is off.
4. Turn off the thermostat.
5. Turn on the gas and purge gas lines of all air.
6. Check for gas leaks on all pipe joints upstream of the gas valve with a soap solution.
7. Turn the thermostat to the highest setting and verify successful ignition and a normal run condition for at least 5 minutes. If the appliance fails to run, see the *Troubleshooting* section.
8. Check for gas leaks on all pipe joints downstream of the gas valve with a soap solution.
9. Turn the thermostat down for at least 30 seconds and then back up again. Verify successful ignition at least five times.
10. Return the thermostat to a normal temperature setting before leaving the installation.



WARNING:

The control module can not be serviced by user. If any faults are detected, the control module must be replaced. If control module has been opened or any attempts to repair are done, the warranty is void.

Operation

Operating Mode Definitions

The following definitions describe the BG1600M operating conditions.

- **Prepurge:** Initial time delay between thermostat contact closure and activation of the spark circuit and pilot valve.
- **Trial for Ignition:** Total time the pilot valve is energized and spark/sense sequence is activated in an attempt to light the pilot. The control attempts to prove flame within the trial-for-ignition time.
- **100% Shutoff:** If the control does not prove the presence of pilot burner flame within the trial for ignition, the spark circuit and pilot valve are de-energized.
- **Recycle:** If 100% shutoff occurs, the control delays for a specific recycle delay period before beginning another trial for ignition (models with recycle only).
- **Run:** Main valve is energized and spark turns off after pilot flame is proven. The main valve remains energized until the thermostat is satisfied.
- **Flameout:** Loss of proven flame. Should a flameout occur, the main valve de-energizes and spark recurs within 2.0 seconds.
- **Lockout:** An internal or external fault has caused the control to de-energize the spark circuit and valve relays. The thermostat contacts must be opened for 30 seconds and then closed to begin another trial for ignition.
- **Inter-Purge:** Period between trials for ignition when both the gas valve and spark are de-activated to allow unburned gas to escape before the next trial.

Sequence of Operation

The heating cycle start when a call for heat from the thermostat supplies 24VAC to the TH terminal. The automatic vent damper (if used) is energized and when fully open, turns on the power to the ignition control. After a 1 second maximum diagnostic period, the spark will start and the pilot valve will turn on, starting with the trial for ignition period.

During the trial for ignition period, the control sparks for 4 seconds while rapidly flashing LED. It then turns off the spark and LED for 1 second while checking pilot flame sense. This cycle will repeat until pilot flame is detected or trial time is over.

When pilot flame is detected, the spark will stop, main valve will turn on and the LED will stay on continuously. The control will remain in this state until

the pilot flame is lost or the call for heat ends. If pilot flame is lost, LED, main and pilot valves are turned off for 0.5 seconds and a new trial for ignition sequence will start.

If pilot flame is not detected during the trial for ignition period, the pilot valve will be shut off. Lockout will occur if your model has no retry. Otherwise, after 5 minutes or 60 minutes (for recycle units only) the control will delay for the specific recycle delay period before beginning another trial for ignition.

Table 1: LED Indications During Normal Operation

Flash Code	Flash Code Indication
Steady On	Flame detected, main burner on
.1 Second On .1 Second Off	Trial time spark on trying to light pilot burner
.25 Second On 1.0 Second Off	Trial time lockout

Troubleshooting

If the system does not function properly, determine the cause using the procedures in this section.

Before proceeding with troubleshooting the system, check the following.

Preliminary Checks

- Are you using resistive wire between the module spark (10) and the pilot connection?
- Are all mechanical and electrical connections tight?
- Is the system wired and ground correctly?
- Is gas inlet pressure per manufacturer's specifications?
- Is the system powered?
- Is the thermostat calling for heat?

LED Error Indications

If the control module internal diagnostics detect a fault it will go to lockout. Spark and both valves will be turned off. The LED will flash the error code .25 seconds on and .25 seconds off for each count of the error code with 1 second off between codes. The control will remain in this condition until power is removed by turning off the call for heat. Codes indicate a problem with the control and it must be replaced.

Table 2: LED Error Indications

Flash Code	Flash Code Description
1	No flame in trial time
2	Flame sense circuit error
3	Pilot valve circuit error
4	Main valve circuit error
5 to 9	Internal control error



WARNING: Risk of Personal Injury.

Do not place face, hands, or other parts of the body in or near the burner area when the LED is flashing (recycle mode). When the LED is flashing, the control may at any time (while in the recycle mode) re-energize the burner control system and ignite the burner which may result in electric shock from contact with the electrode or severe burn injury from firing of the burner.

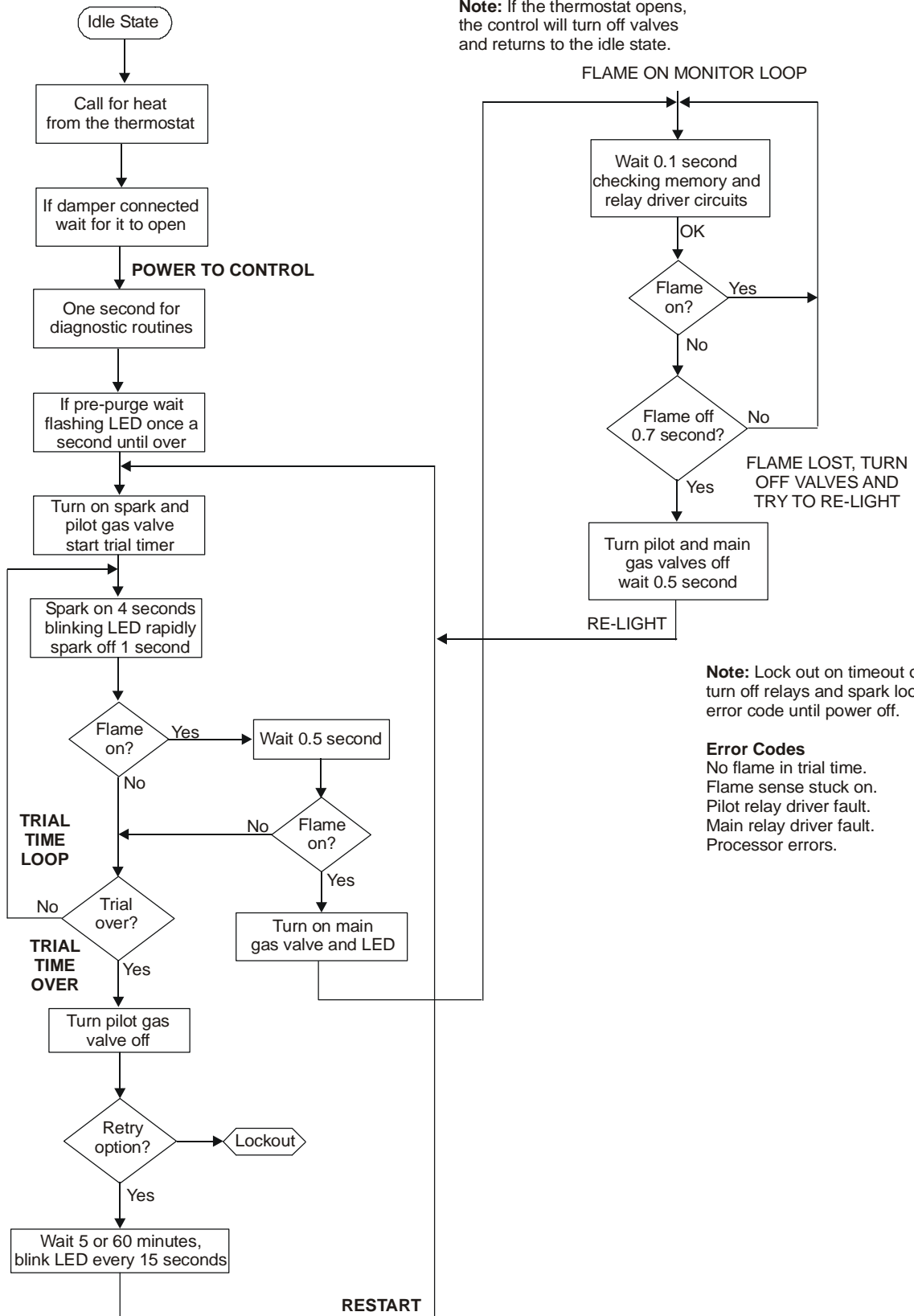

Figure 5: Sequence of Operation

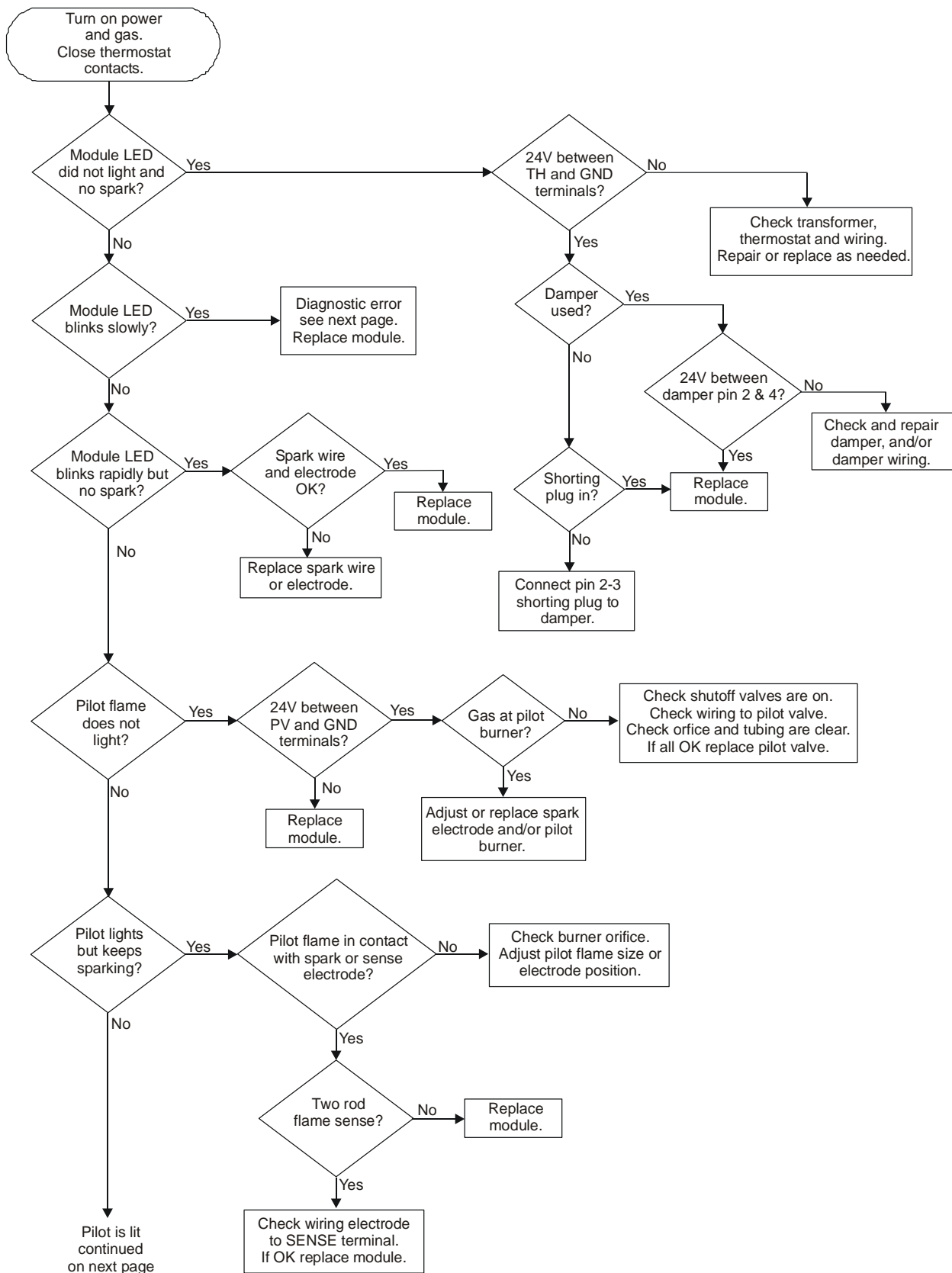

Figure 6: Troubleshooting Flow Chart (1 of 2)

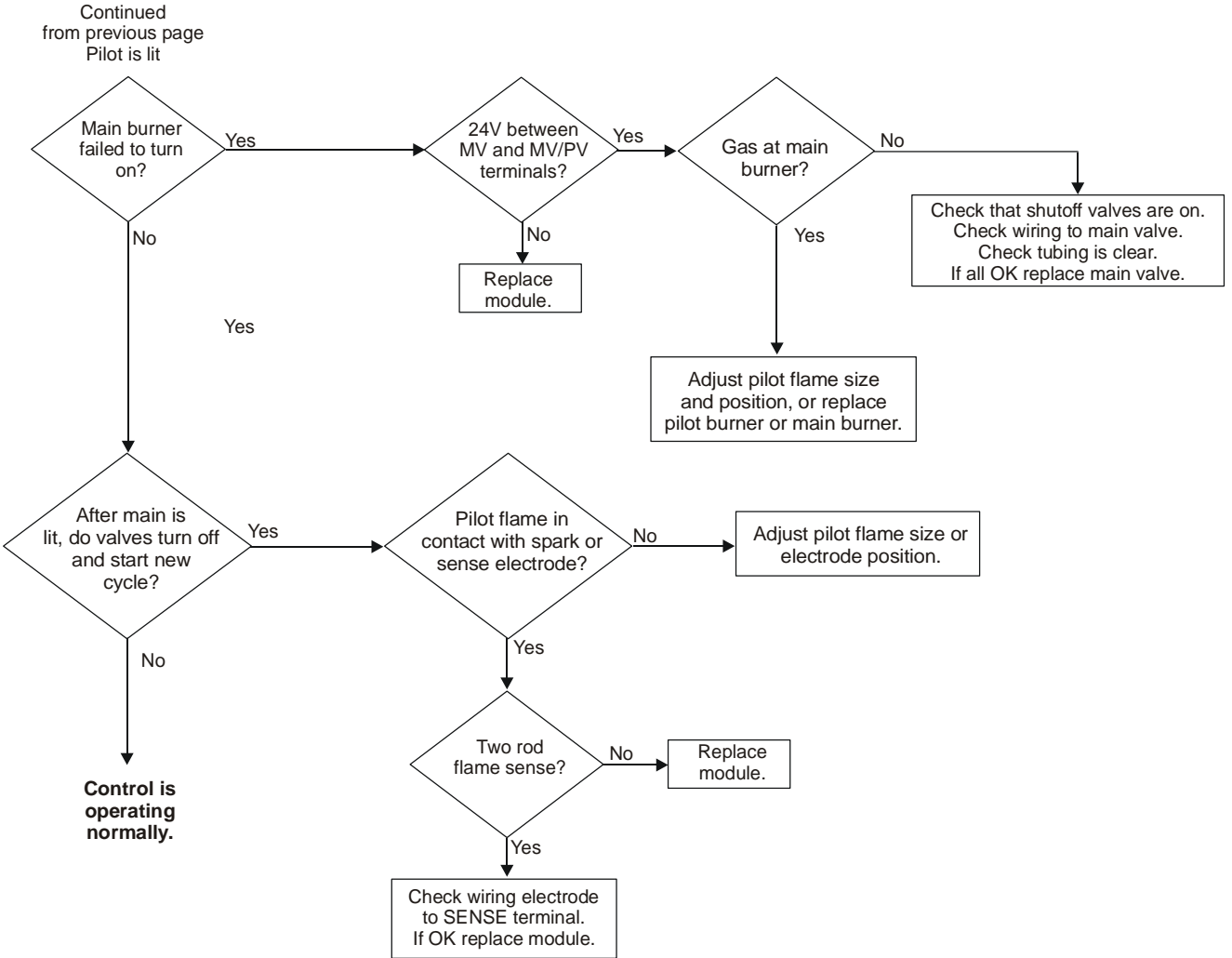

Figure 7: Troubleshooting Flow Chart (2 of 2)

Maintenance Requirements in Severe Environments

Regular preventive maintenance is important in any application, but especially so in commercial cooking, agricultural, and industrial applications because:

- In many such applications, particularly commercial cooking, the equipment operates 100,000 to 200,000 cycles per year. Such heavy cycling can wear out the gas control in one to two years. A normal forced air furnace, for which the controls were originally intended, typically operates less than 20,000 cycles per year.
- Exposure to water, dirt, chemicals, and heat can damage the ignition control module or the gas control and shut down the control system. A NEMA 4 enclosure can reduce exposure to environmental contaminants.



WARNING: Risk of Explosion or Fire. Do not attempt to take the ignition control module apart or to clean it. Improper reassembly and cleaning may cause unreliable operation, which can lead to an explosion or fire, and may result in severe injury, property damage or death.

Maintenance frequency must be determined individually for each application. Some considerations are:

- Cycling Frequency – Appliances that may cycle more than 20,000 times annually should be checked monthly.
- Intermittent Use – Appliances that are used seasonally should be checked before shutdown and again before the next use.
- Consequence of Unexpected Shutdown – Where the cost of an unexpected shutdown would be high, the system should be checked more often.
- Dust, Wet, or Corrosive Environment – Since these environments can cause the controls to deteriorate more rapidly, the system should be checked more often.

Repairs and Replacement



CAUTION: Risk of Electric Shock.

Disconnect power supply before making electrical connections to avoid electric shock.



WARNING: Risk of Explosion or Fire.

Shut off the gas supply at the main manual shutoff valve before installing or servicing the control. Failure to shut off the gas supply can result in the release of gas during installation or servicing, which can lead to an explosion or fire, and may result in severe injury or death.



WARNING: Risk of Explosion, Fire, or Electric Shock. Label all wires before they are disconnected when replacing or servicing the BG1600M. Wiring errors can cause improper or dangerous operation and may result in an explosion, fire, or electric shock leading to severe personal injury or death.

Field repairs must not be made to the BG1600M control. Any attempt to repair this assembly voids the manufacturer's warranty. For a replacement control, contact the original equipment manufacturer or the nearest BASO Gas Products distributor.

All other accessories, such as flame sensors, electrode assemblies, pilot assemblies, and leads can be obtained through the original equipment manufacturer or a BASO Gas Products distributor.

Technical Specification

Product	BG1600M Intermittent Pilot Ignition Control	
Ignition Type	Indirect	
Ignition Source	High voltage spark, capacitive discharge	
High Voltage Cable Maximum Length	48 in. (1,220 mm) (Resistive wire recommended, rated for at least 15kV.)	
Flame Sense Cable Maximum Length	48 in. (1,220 mm)	
Flame Detection Means	Flame Rectification	
Flame Detection Type	Local or Remote	
Minimum Flame Current	0.15 microamperes	
Flame Failure Response Time	2 seconds maximum	
Maximum Spark Gap	0.2 in. (5.1 mm)	
Number of Trials Before 100% Shutoff	One	
Trial-for-Ignition Time	Infinite, 5, 10, 15, 20, 25, 30, 60, or 90 seconds	
Prepurge Time	0, 10, 15, 30, or 45 seconds	
Automatic Recycle Delay Period	None 5 minutes 60 minutes	
Power Requirements	Control:	24 VAC (+/- 20%), 50/60 Hz
	Operation Current:	0.2 A nominal + valves
Contact Rating	Main Valve:	2 A maximum
	Pilot Valve:	1 A maximum
Wiring Connections	1/4 in. (6.35 mm) male spade	
Maximum Firing Rate	400,000 Btu/hr (117 kW)	
Ambient Operating and Storage Temperature	-40 to 170°F (-40 to 77°C)	
Humidity	95% RH noncondensing	
Type of Gas	Natural, Liquefied Petroleum (LP), Manufactured, Mixed or LP Gas-Air Mixture	
Packaging	Bulk pack supplied to original equipment manufacturer (25 per box) Individual pack (1 per box) Individual overpack (20 per box)	
Pack Weight	Bulk pack 14 lb (6.36 kg) Individual pack 1 lb (.454 kg) Individual overpack 18 lb (8.17 kg)	
Agency Listing	CSA Certificate Number 246569-2161442	
Specifications Standards	ANSI Standard Z21.20 CAN/CSA-C22.2 No. 199	

The performance specifications are nominal and conform to acceptable industry standards. All agency certification of BASO products is performed under dry and controlled indoor environmental conditions. Use of BASO products beyond these conditions is not recommended and may void the warranty. If the product is exposed to water (dripping, spraying, rain, etc.) or other harsh environments, it must be protected. The original equipment manufacturer or end user is responsible for the correct application of BASO products. For questionable applications, please consult BASO Gas Products LLC. BASO Gas Products LLC shall not be liable for damages or product malfunctions resulting from misapplication or misuse of its products.

1007 South 12th Street
PO Box 170
Watertown, WI 53094
1-877-227-6427

Published in U.S.A.
www.baso.com