



BGA109 Series Shutoff Gas Valve

Applications

The BGA Series shutoff gas valve is an electrically operated gas valve that will open on a demand signal from a thermostat or other controlling device and automatically close once the signal is removed. Typical applications include heaters, wall furnaces, commercial cooking equipment, outdoor fire pits units and similar applications. The BGA Series can be used with natural gas and LP gas at pressures up to 0.5 psi. Its compact size permits installation in space restrictive applications.

Installation

IMPORTANT: Only qualified personnel should install or service BASO® Gas Products. These instructions are a guide for such personnel. Carefully follow all instructions in this document and all instructions for the appliance.

IMPORTANT: Make all gas installations in accordance with applicable local, national, and regional regulations.



CAUTION: Risk of Electric Shock.
Disconnect power supply before making electrical connections to avoid electric shock.



WARNING: Risk of Explosion or Fire.
Shut off the gas supply at the main manual shutoff valve before installing or servicing the BGA Series. Failure to shut off the gas supply can result in the release of gas during installation or servicing, which can lead to an explosion or fire, and may result in severe personal injury or death.



WARNING: Risk of Explosion, Fire, or Electric Shock. Label all wires before they are disconnected when replacing or servicing the BGA Series. Wiring errors can cause improper or dangerous operation and may result in an explosion, fire, or electric shock leading to severe personal injury or death.

IMPORTANT: Verify that the valve is installed only in applications where the specified maximum ambient (surface) temperature and maximum operating pressure does not exceed the limits in the *Technical Specifications* section.

To install the BGA Series valve:

1. Shut off power to the appliance.
2. Shut off the gas at the main manual shutoff valve.
3. Label each wire with the correct terminal designation prior to disconnection.
4. Compare the voltage on the valve with the power source voltage to ensure the correct unit is being installed. For valves with 25-volt coils, use a National Electrical Code (NEC), Class 2 transformer.
Note: The transformer must be mounted to a grounded metal enclosure.
5. Ensure that the gas flows through the valve body in the direction indicated by the "IN" on the valve body. If the valve is installed with the gas flow in the opposite direction, leakage can occur.

IMPORTANT: Do not use a wrench on any surface other than the flats provided at the inlet and outlet ends of the valve body. The BGA Series may be damaged in the mounting process if a wrench is used on any other surface. Using a wrench incorrectly may void the warranty.

6. The BGA Series valve may be mounted on a horizontal manifold with the solenoid coils pointed up (vertical) or in any position not exceeding 90° from the vertical. The valve may also be mounted on a vertical manifold in any position around its axis (see Figure 1). **Do not** install the solenoid coil upside down. Install horizontally wherever possible.

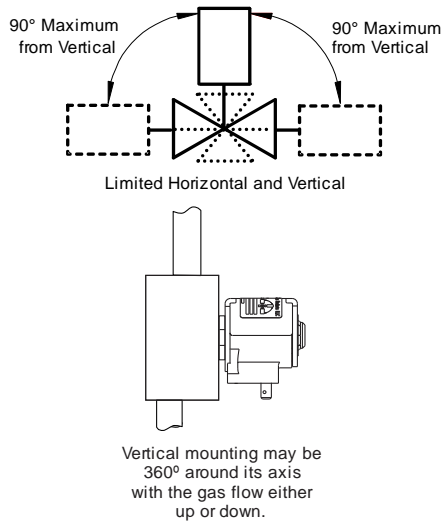

Figure 1: BGA Series Mounting Positions

7. Installer must be a trained, experienced, flame safeguard control technician. Threads of the pipe and nipples must be smooth and free of tears and burrs. A sediment trap should also be installed in accordance with the National Fuel Gas Code NFPA 54 (see Figure 6). Mount the valve to the pipework, using a quality rated pipe tape, UL listed seal material rated for gasoline, propane, and other gases. If not available, a quality grade pipe dope, a light amount on the male threads, start two threads away from the first engaging thread. If pipe dope lodges on the valve seat, it will prevent proper closure. Remove excess compound after mounting the valve to the pipework.
8. Thread pipe (the amount shown in Table 1) for insertion into the control. Do not thread the pipe too far. Valve distortion or malfunction may result if the pipe is inserted too deeply.

Table 1: NPT Pipe Thread Length into Valve

Pipe Size (NPT)	Thread Pipe Amount (in.)	Maximum Depth Pipe (in.)
1/8	1/2	1/4

9. For any threaded connections, threads of pipe and nipples must be smooth and free of tears and burrs. Steam clean all piping inside diameter to remove foreign substances such as cutting oil or thread chips before installing into the valve. Apply a moderate amount of good quality pipe compound (do not use Teflon tape) to pipe only, leaving two end threads bare (see Figure 2). On LP installation, use compound resistant to LP gas.

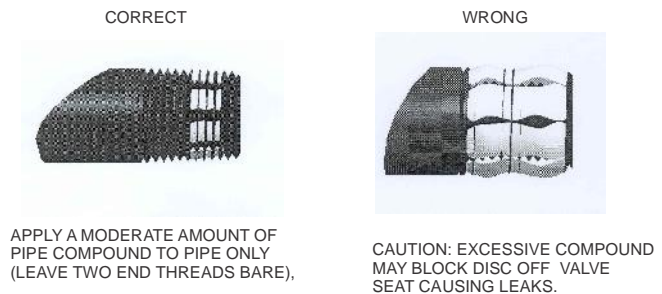

Figure 2: Use a Moderate Amount of Pipe Compound

10. Connect pipe to gas control inlet and outlet. Use a wrench on the square ends of the control. If a flange is used, place the wrench on the flange rather than on the control. This process should be used for both the installation and removal of the valve in a gas system (see Figure 3).

APPLY WRENCH TO THE FLATS
FROM THE BOTTOM OF THE
GAS CONTROL VALVE

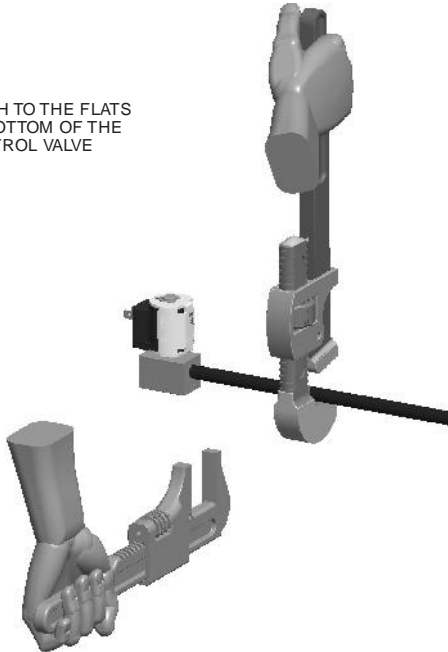

Figure 3: Proper Use of Wrench on Gas Control

****DO NOT USE THE COIL FOR LEVERAGE****



WARNING: Risk of Explosion or Fire.

Verify that there are no gas leaks by testing with appropriate equipment. Never use a match or lighter to test for the presence of gas. Failure to test properly can lead to an explosion or fire and may result in severe personal injury or death.

11. Check for leakage:

- a. Shut off the gas at the main manual shutoff valve and open the pressure connection between the manual shutoff valve and the BGA Series valve.
- b. Connect air tubing with a maximum pressure of 1-1/2 times the valve's maximum operating pressure (as indicated on the valve) to the opened pressure connection.
- c. Paint all valve body connections with a rich soap and water solution.

If bubbles occur, this is an indication of a leak. To stop a leak, tighten joints and connections. Replace the part if the leak cannot be stopped.

If bubbles do not occur, remove the air tubing and close the pressure connection.

12. Make wiring connections. Refer to the *Wiring* section for specific wiring instructions.

13. Perform the *Checkout* section before leaving the installation.

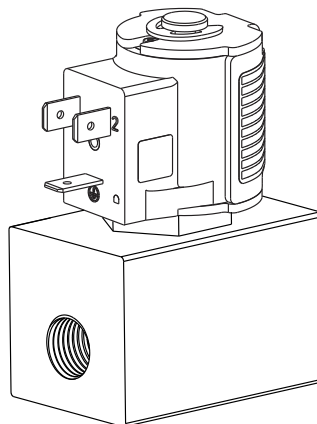

BGA109

Figure 4: BGA109 Series Gas Valve

Wiring



WARNING: Risk of Shock.

Disconnect the power supply before making electrical connections to avoid electrical shock or equipment damage. Ensure that the operating voltage is identical to the information on the product identification label.

The BGA Series valve is supplied with 3-tab and 2-tab electrical connections. The tabs of the solenoid coil are male tag terminals, and electrical connections should be made using 1/4 in. (6.35 x 0.8 mm) female, fully insulated push-on terminals. The earth ground terminal is clearly labeled with the earth ground symbol (see Figure 5).

Note: Electrical connections can also be made using electrical plugs (DIN 43650 [ISO 4400]) which are available from any BASO Gas Products distributor.

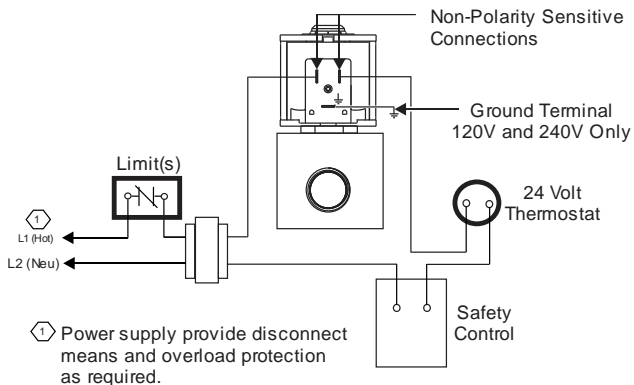

Figure 5: Electrical Connections

Setup and Adjustments

Checkout

IMPORTANT: All adjustments must be made in conjunction with the gas appliance and in accordance with the appliance manufacturer's instructions. Only authorized personnel should make adjustments.



WARNING: Risk of Explosion or Fire.

Follow this or an equivalent checkout procedure after installation. Before leaving the installation, verify that the gas valve functions properly and that the system has no gas leaks. Gas leaks can lead to an explosion or fire, and may result in severe personal injury or death.

Make sure all components are functioning properly by performing the following test.

1. Test all joints and connections for leaks with a rich soap and water solution. If leaks occur, see Step 11 in the *Installation* section.
2. Close the main manual shutoff valve and wait at least 5 minutes for unburned gas to escape from the appliance, and then reopen the shutoff valve.
3. Turn on the main electrical power switch and close the thermostat contacts. The appliance should operate in accordance with the manufacturer's specified sequence of operation.
4. Turn the thermostat to a low dial setting to open the contacts. All burner flames should be extinguished. Repeat Steps 3 and 4 in this section at least three times.
5. Return the thermostat to a normal setting before leaving the installation.

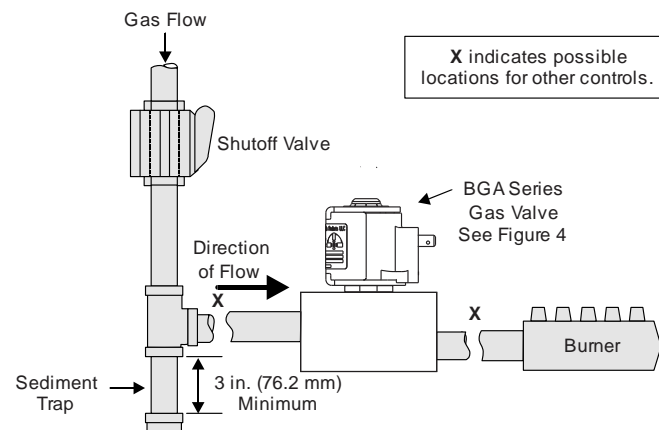

Figure 6: Typical BGA Installation

Repairs and Replacement

Table 1: Replacement Solenoid Coil

(BGA109 Standard coil)

Part Number	Description
RSDA95A-12	12 VDC; 2-tab 10.5 VA Coil
RSDA95A-25	25 VAC; 50/60 Hz; 3-tab 10.5 VA Coil
RSDA95A-25V	25 VDC; 3-tab 11.5 VA Coil
RSDA95A-120	120 VAC; 50/60 Hz; 3-tab 10.5 VA Coil
RSDA95A-240	240 VAC; 50/60 Hz; 3-tab 10.5 VA Coil

(BGA109 Encapsulated Coil)

Part Number	Description
RSDA95A-E12	12 VDC; 2-tab 10.5 VA Coil
RSDA95A-E25	25 VAC; 50/60 Hz; 3-tab 10.5 VA Coil
RSDA95A-E120	120 VAC; 50/60 Hz; 3-tab 10.5 VA Coil
RSDA95A-E240	240 VAC; 50/60 Hz; 3-tab 10.5 VA Coil



CAUTION: Risk of Electric Shock.

Disconnect power supply before making electrical connections to avoid electric shock.



WARNING: Risk of Explosion or Fire.

Shut off the gas supply at the main manual shutoff valve before installing or servicing the BGA Series. Failure to shut off the gas supply can result in the release of gas during installation or servicing, which can lead to an explosion or fire, and may result in severe personal injury or death.



WARNING: Risk of Explosion, Fire, or Electric Shock. Label all wires before they are disconnected when replacing or servicing the BGA Series. Wiring errors can cause improper or dangerous operation and may result in an explosion, fire, or electric shock leading to severe personal injury or death.

Field repairs **must not** be made to the BGA Series valve. Any attempt to repair this assembly voids the manufacturer's warranty. For a replacement valve, contact the original equipment manufacturer or the nearest BASO Gas Products distributor.

Technical Specifications

Product	BGA109 Series Shutoff Gas Valve
Types of Gas	Natural Gas or LP Gas
Maximum Operating Pressure	0.5 psi
Permissible Ambient (Surface) Temperature	0 to 175°F (-18 to 79°C)
Body Connections	1/8 NPT
Electrical Ratings	<u>BGA109</u> 12 VDC, 0.875A 25 VAC, 50/60 Hz, 0.42A 120 VAC, 50/60 Hz, 0.088A 240 VAC, 50/60 Hz, 0.044A
Pressure Connections	1/8 NPT left, or right (Optional)
Operating Time Rating	100% Continuous
Valve Timings	Closing Time 1 Second; Opening Time 1 Second; Dead Time <1 Second
Power Ratings	10.5 VA per Coil
Electrical Connections	3-Tab Solenoid Coil, 2 x 1/4 in. (6.35 mm) + 1/4 in. (6.35 mm) Earth Ground 2-Tab Solenoid Coil, 2 x 1/4 in. (6.35 mm)
Valve Torsion Group	Group 2 (EN 161)
Coil Insulation Class	Class F
Packaging	Bulk pack supplied to original equipment manufacturer individual pack optional).
Bulk Pack Quantity	40
Bulk Pack Weight	36 lbs (16.3 kg)
Agency Listing	CSA Certificate Number 229521-1656058
Specification Standards	UL Standard 429 Standards Complying with EMC Directive Standards Complying with Low Voltage Directive ANSI Standards Z21.21 Canadian Standards CAN1-6.5

Performance specifications are nominal and conform to acceptable industry standards. All agency certification of BASO products is performed under dry and controlled indoor environmental conditions. Use of BASO products beyond these conditions is not recommended and may void the warranty. Product must be protected if exposed to water (dripping, spraying, rain, etc.) or other harsh environments. The original equipment manufacturer or end user is responsible for the correct application of BASO products. Consult BASO Gas Products LLC for questionable applications. BASO Gas Products LLC shall not be liable for damages or product malfunctions resulting from misapplication or misuse of its products.

Refer to the *BGA158, BGA171, and BGA110 Series Shutoff Gas Valve Product Bulletin (BASO-PB-BGA)* for necessary information on operating and performance specifications for this product.



BASO Gas Products LLC

450 East Horseshoe Road
PO Box 170
Watertown, WI 53094
1-877-227-6427 (1-877-BASOGAS)

www.baso.com
Published in U.S.A.