



BGH2UNCNTRLHT-01 Universal Hot Surface Ignition Control

Application

The BASO Gas Products BGH2UNCNTRLHT-01 Universal Series Hot Surface Ignition (HSI) control is microprocessor based with timed ignition and suited for replacement or new applications. Applications for hot surface ignition modules include agricultural equipment, space heaters, furnaces, residential/commercial boilers, water heaters, pool and spa heaters, and a variety of other commercial cooking equipment.

This control includes a 5 position DIP switch allowing up to 32 programmable pre-defined timing selections to retrofit other Hot Surface Ignitions with flame sensing rectification, such as: Johnson Controls, Honeywell, White Rodgers, Fenwal, and Robertshaw.

The BGH2UNCNTRLHT-01 works with single-rod or dual-rod sensing to prove a flame. The control has a continuous and precise monitoring of the HSI element, wiring, and gas valve, shutting down in the event of a failure. For a complete listing of specifications, refer to the *Technical Specifications* section.

Installation

IMPORTANT: Only qualified personnel should install or service BASO Gas Products®. These instructions are a guide for such personnel. Carefully follow all instructions for the appliance.

IMPORTANT: Make all gas installations in accordance with applicable local, national, and regional regulations.



WARNING: Risk of Explosion or Fire.

Do not install the control in an area that is exposed to water (for example, dripping, spraying, rain). Do not use the control if it has been exposed to water. Exposure to water may cause malfunction and can lead to an explosion or fire and may result in severe personal injury or death.

Table 1: BGH2UNCNTRLHT-01 Universal Cross Reference

Switch Positions ON	Switch Positions OFF	White-Rodgers	Robersshaw	Honeywell	Fenwal
none	1,2,3,4,5	50E47-150 to 159 50E47-350 to 359			
5	1,2,3,4	50E47-140 to 149 50E47-340 to 349			
4	1,2,3,5	50F47-150 to 159 50F47-350 to 359			
4,5	1,2,3	50F47-140 to 149 50F47-340 to 349			05-356265-153(d,g) 05-356265-154(d,g)
3	1,2,4,5	50E47-170 to 179 50E47-370 to 379 50F47-170 to 179 50F47-370 to 379	HS780-34NL-306A(a,c) HS780-34NL-308A(a,c) HS780-34NL-312A(c,d) HS780-34NR-306A(a,c) HS780-34NR-308A(a,c) HS780-34NR-312A(c,d)	S89H1011(a,c) S89G1013(a,c) S89G1021(c,d) S89H1029(c,d) S89G1047(a,c)	
3,5	1,2,4,	50E47-160 to 169 50E47-360 to 369 50F47-160 to 169 50F47-360 to 369	HS780-17NR-306A(a,b) HS780-17NR-308A(a,b) HS780-17NL-308A(a,b)		05-356265-053(c,d) 05-356265-054(c,d) 05-356265-055(c,d)
3,4	1,2,5			S8910U S890H1010(a,f) S890G1011(a,f) S890H1028(d,f) S890G1029(d,f) S890G1037(a,f)	
3,4,5	1,2				

Note: For timing parameters see Table 2.

- (a) The BGH2UNCNTRLHT-01 Universal and the referenced control ignition trial times are different; however, the ignition trial time is within the design tolerance of the referenced control.
- (b) The BGH2UNCNTRLHT-01 Universal between trial purge time is longer than that of the referenced control.
- (c) The BGH2UNCNTRLHT-01 Universal between trial purge and igniter warmup times is longer than those of the referenced control.
- (d) The BGH2UNCNTRLHT-01 Universal ignition trial time is shorter than that of the referenced control. Be sure to observe appliance operation to assure reliable performance.
- (e) The BGH2UNCNTRLHT-01 Universal pre-purge time is longer than that of the referenced control
- (f) The BGH2UNCNTRLHT-01 Universal pre-purge and between trial purge times are longer than those of the referenced control.
- (g) The BGH2UNCNTRLHT-01 Universal pre-purge, between trial purge, and igniter warmup times are longer than those of the referenced control.

Table 1: BGH2UNCNTRLHT-01 Universal Cross Reference

Switch Positions ON	Switch Positions OFF	White-Rodgers	Robersshaw	Honeywell	Fenwal
2	1,3,4,5	50E47-130 to 139 50E47-330 to 339			
2,5	1,3,4	50E47-120 to 129 50E47-320 to 329			
2,4	1,3,5	50F47-130 to 139 50F47-330 to 339			
2,4,5	1,3	50F47-120 to 129 50F47-320 to 329			05-356225-153(d,g) 05-356225-154(d,g) 05-356225-155(d,g)
2,3	1,4,5	50E47-110 to 119 50E47-310 to 319 50F47-110 to 119 50F47-310 to 319			
2,3,5	1,4	50E47-101 to 109 50E47-301 to 309 50F47-101 to 109 50F47-301 to 309	HS780-17NL-108A(a)		05-356225-053(c,d) 05-356225-054(c,d) 05-356225-055(c,d)
2,3,4	1,5			8910U S890D1006(a,e) S890C1007(a,e)	
2,3,4,5	1		HS780-34NL-108A(a)	S89D1002(a) S89C1004(a) S89J1008(a) S89C1012(a)	
1	2,3,4,5	50E47-50 to 59 50E47-250 to 259			

Note: For timing parameters see Table 2.

- (a) The BGH2UNCNTRLHT-01 Universal and the referenced control ignition trial times are different; however, the ignition trial time is within the design tolerance of the referenced control.
- (b) The BGH2UNCNTRLHT-01 Universal between trial purge time is longer than that of the referenced control.
- (c) The BGH2UNCNTRLHT-01 Universal between trial purge and igniter warmup times is longer than those of the referenced control.
- (d) The BGH2UNCNTRLHT-01 Universal ignition trial time is shorter than that of the referenced control. Be sure to observe appliance operation to assure reliable performance.
- (e) The BGH2UNCNTRLHT-01 Universal pre-purge time is longer than that of the referenced control
- (f) The BGH2UNCNTRLHT-01 Universal pre-purge and between trial purge times are longer than those of the referenced control.
- (g) The BGH2UNCNTRLHT-01 Universal pre-purge, between trial purge, and igniter warmup times are longer than those of the referenced control.

Table 1: BGH2UNCNTRLHT-01 Universal Cross Reference

Switch Positions ON	Switch Positions OFF	White-Rodgers	Robershaw	Honeywell	Fenwal
1,5	2,3,4	50E47-40 to 49 50E47-240 to 249			
1,4	2,3,5	50F47-50 to 59 50F47-250 to 259			
1,4,5	2,3	50F47-40 to 49 50F47-240 to 249			05-356265-151(a,g) 05-356265-152(a,g)
1,3	2,4,5	50E47-70 to 79 50E47-270 to 279 50F47-70 to 79 50F47-270 to 279	HS780-34NL-304A(c)	S89H1003(c) S89G1005(c)	
1,3,5	2,4	50E47-60 to 69 50E47-260 to 269 50F47-60 to 69 50F47-260 to 269	HS780-17NL-304A(b)		05-356265-051(a,c) 05-356265-052(a,c)
1,3,4	2,5			S8910U S890G1003(f) S890H1002(f)	
1,3,4,5	2				
1,2	3,4,5	50E47-30 to 39 50E47-230 to 239			
1,2,5	3,4	50E47-20 to 29 50E47-220 to 229			
1,2,4	3,5	50F47-30 to 39 50F47-230 to 239			
1,2,4,5	3	50F47-20 to 29 50F47-220 to 229			05-356225-151(a,g) 05-356225-152(a,g)

Note: For timing parameters see Table 2.

- (a) The BGH2UNCNTRLHT-01 Universal and the referenced control ignition trial times are different; however, the ignition trial time is within the design tolerance of the referenced control.
- (b) The BGH2UNCNTRLHT-01 Universal between trial purge time is longer than that of the referenced control.
- (c) The BGH2UNCNTRLHT-01 Universal between trial purge and igniter warmup times is longer than those of the referenced control.
- (d) The BGH2UNCNTRLHT-01 Universal ignition trial time is shorter than that of the referenced control. Be sure to observe appliance operation to assure reliable performance.
- (e) The BGH2UNCNTRLHT-01 Universal pre-purge time is longer than that of the referenced control
- (f) The BGH2UNCNTRLHT-01 Universal pre-purge and between trial purge times are longer than those of the referenced control.
- (g) The BGH2UNCNTRLHT-01 Universal pre-purge, between trial purge, and igniter warmup times are longer than those of the referenced control.

Table 1: BGH2UNCNTRLHT-01 Universal Cross Reference

Switch Positions ON	Switch Positions OFF	White-Rodgers	Robershaw	Honeywell	Fenwal
1,2,3	4,5	50E47-10 to 19 50E47-210 to 219 50F47-10 to 19 50F47-210 to 219			
1,2,3,5	4	50E47-1 to 9 50E47-201 to 209 50F47-1 to 9 50F47-201 to 209	HS780-17NL-104A HS780-17NR-104A		05-356225-051(a,c) 05-356225-052(a,c)
1,2,3,4	5			S8910U	
1,2,3,4,5	none		HS780-34NR-104A	S89C1046 S89C1103	

Note: For timing parameters see Table 2.

- (a) The BGH2UNCNTRLHT-01 Universal and the referenced control ignition trial times are different; however, the ignition trial time is within the design tolerance of the referenced control.
- (b) The BGH2UNCNTRLHT-01 Universal between trial purge time is longer than that of the referenced control.
- (c) The BGH2UNCNTRLHT-01 Universal between trial purge and igniter warmup times is longer than those of the referenced control.
- (d) The BGH2UNCNTRLHT-01 Universal ignition trial time is shorter than that of the referenced control. Be sure to observe appliance operation to assure reliable performance.
- (e) The BGH2UNCNTRLHT-01 Universal pre-purge time is longer than that of the referenced control
- (f) The BGH2UNCNTRLHT-01 Universal pre-purge and between trial purge times are longer than those of the referenced control.
- (g) The BGH2UNCNTRLHT-01 Universal pre-purge, between trial purge, and igniter warmup times are longer than those of the referenced control.

Replacing the Existing Ignition Control



CAUTION: Risk of Electric Shock.

Disconnect power supply before making electrical connections to avoid electric shock.



WARNING: Risk of Explosion or Fire.

Shut off the gas supply at the main manual shutoff valve before installing or servicing the control. Failure to shut off the gas supply can result in the release of gas during installation or servicing, which can lead to an explosion or fire, and may result in severe personal injury or death.



WARNING: Risk of Explosion, Fire, or Electric Shock. Label all wires before they are disconnected when replacing or servicing the control. Wiring errors can cause improper or dangerous operation and may result in an explosion, fire, or electric shock leading to severe personal injury or death.

To remove the existing ignition control:

1. Shut off power to the appliance.
2. Turn off the gas at the main manual shutoff valve adjacent to the appliance. (If the manual shutoff valve services more than one appliance, be sure to light the other pilots before leaving the installation.)
3. Label each wire with the correct terminal designation prior to disconnection.
4. Disconnect the wires from the existing control.
5. Remove the screws holding the ignition control to the valve (if direct valve-mount model) or remove the screws holding the control to the appliance chassis (if foot-mount model).
6. Remove the old ignition control and discard.

IMPORTANT: Do not mount the control where it can be exposed to direct infrared radiation from the main burner or to temperatures in excess of the maximum product temperature rating.

7. Mount the new control with #6 sheet metal or machine screws through the mounting holes in the enclosure.
8. Refer to the *Wiring* section for electrical connections and wiring diagrams. Perform the *Checkout* section before leaving the installation.
9. Check all wiring for proper connections and make sure your system is properly grounded.

Wiring



WARNING: Risk of Explosion or Fire.

Locate all safety, limit, and operating controls in series with the thermostat terminal (TH) on the ignition control. Improper installation may cause gas leaks, which can lead to an explosion or fire and may result in severe personal injury or death.

Refer to Figure 1 and Figure 2 for wiring diagrams. All wiring should be in accordance with the National Electrical Code (NEC) and all other local codes and regulations.

Check the voltage rating marked on the control and make sure it is suited to the application. Use a Class 2 transformer capable of providing 24 VAC under maximum load, including valves. A transformer having excessive primary impedance due to poor coupling affects the ignition potential.

The control is supplied with a jumper wire between Sense (terminal 10) and 120/240V Hot HSI (terminal 7). With the jumper in, flame is sensed through the high voltage HSI (Hot Surface Igniter) wire. The jumper must be removed for external flame sense and the sense electrode wired to the Sense terminal.



WARNING: Risk of Electric Shock.

Before applying power to the control, connect all wires properly to the controller. Verify the controller is properly grounded. Failure to follow this procedure can cause electric shock and may result in severe personal injury or death.

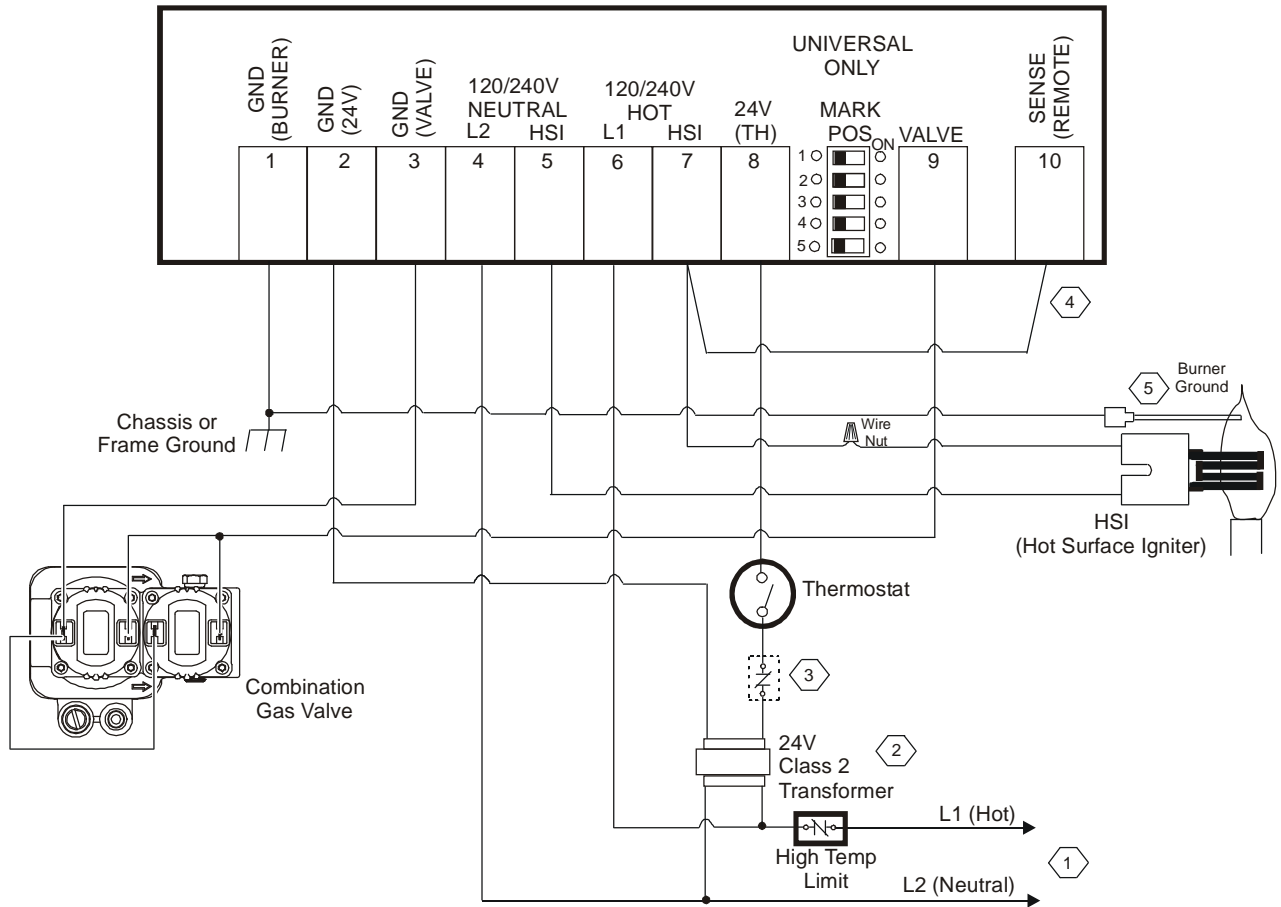

- ① Power Supply. Provides disconnect means and overload protection as required.
- ② The controls 24V circuit must not be in the ground leg to the transformer.
- ③ Alternate location for limit to the controller.
- ④ For Internal Flame Sense circuits, check that the jumper wire is connected between HSI HOT (terminal 7) and SENSE REMOTE (terminal 10).
- ⑤ Ensure the burner ground is in the pilot flame (3/8" [9mm] to 1/2" [12.7mm]) for proper sensing signal.

Figure 1: Typical Wiring for BGH2UNCNTRLHT-01 with Internal Flame Sense

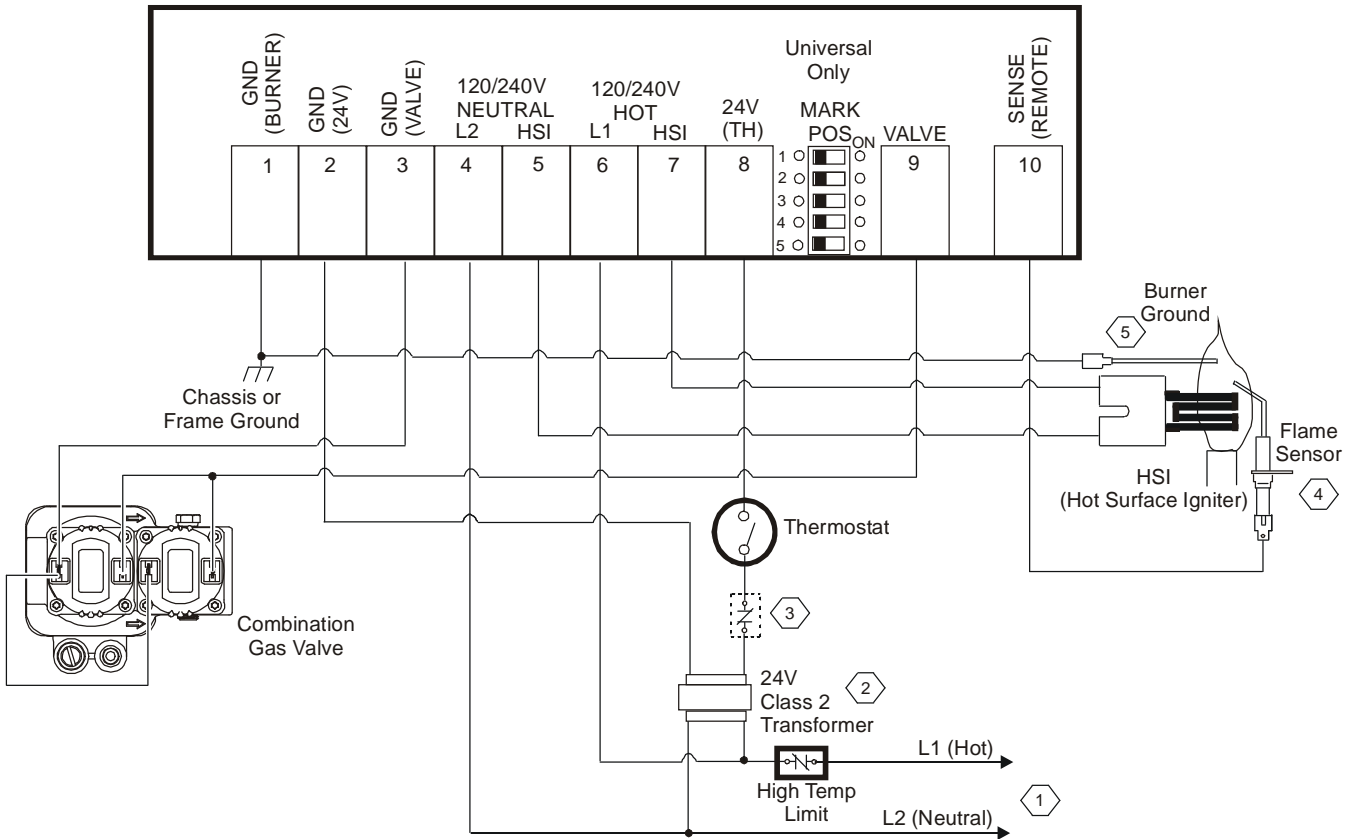

- ① Power Supply. Provides disconnect means and overload protection as required.
- ② The controls 24V circuit must not be in the ground leg to the transformer.
- ③ Alternate location for limit to the controller.
- ④ Check for the sensor tip of the Remote Flame Sensor is 3/8" (9 mm) to 1/2" (12.7 mm) in the flame for proper sensing signal.
- ⑤ Ensure the burner ground is in the pilot flame (3/8" [9mm] to 1/2" [12.7mm]) for proper sensing signal.

Figure 2: Typical Wiring for BGH2UNCNTRLHT-01 with Remote Flame Sense.

Setup and Adjustments

Select Dip Switch Positions

A 5 position dip switch is provided on the controller to allow for field programming of 1 to 32 possible pre-defined sets of timing sequences. Select a predefined timing sequence from Table 1 and then set the dip switches on the control.

To change the settings, remove power from the circuit board, change settings and re-apply power to the circuit board.

The dip switches remain active until 10 consecutive power cycles occur without a change in any dip switch setting. Once this occurs, dip switches become inactive and cannot further be used to change timing specifications.

Table 2: BGHUNCNTRLHT-01 Universal HSIC Parameters/Dip Switch Positions

5 Position Dip Switch Settings		HSIC Parameters				
ON	OFF	*Warmup	Pre-Purge	Between Purge	Ignition Trial Time	No. of Trials
		(Sec.)	(Sec.)	(Sec.)	(Sec.)	#
None	1,2,3,4,5	45	30	90	7	3
5	1,2,3,4	17	30	90	7	3
4	1,2,3,5	45	17	77	7	3
4,5	1,2,3	17	17	77	7	3
3	1,2,4,5	45	None	60	7	3
3,5	1,2,4	17	None	60	7	3
3,4	1,2,5	34	32	96	7	3
3,4,5	1,2	34	None	None	7	3
2	1,3,4,5	45	30	None	7	1
2,5	1,3,4	17	30	None	7	1
2,4	1,3,5	45	17	None	7	1
2,4,5	1,3	17	17	None	7	1
2,3	1,4,5	45	None	None	7	1
2,3,5	1,4	17	None	None	7	1
2,3,4	1,5	34	32	None	7	1
2,3,4,5	1	34	None	None	7	1
1	2,3,4,5	45	30	90	4	3
1,5	2,3,4	17	30	90	4	3
1,4	2,3,5	45	17	77	4	3
1,4,5	2,3	17	17	77	4	3
1,3	2,4,5	45	0	60	4	3
1,3,5	2,4	17	0	60	4	3
1,3,4	2,5	34	32	96	4	3
1,3,4,5	2	34	0	0	4	3
1,2	3,4,5	45	30	None	4	1
1,2,5	3,4	17	30	0	4	1
1,2,4	3,5	45	17	0	4	1
1,2,4,5	3	17	17	0	4	1
1,2,3	4,5	45	0	0	4	1
1,2,3,5	4	17	0	0	4	1
1,2,3,4	5	34	32	0	4	1
1,2,3,4,5	None	34	0	0	4	1

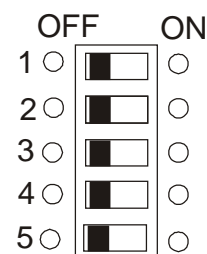

Figure 3: 5 Position Dip Switch

Switch settings shown with all 5 switches in the OFF positions.

*Warmup time is timed ignition.

Checkout



WARNING: Risk of Explosion or Fire.

Verify that there are no gas leaks by testing with appropriate equipment. Never use a match or lighter to test for the presence of gas. Failure to test properly can lead to an explosion or fire and may result in severe personal injury or death.



WARNING:

The control module can not be serviced by user. If any faults are detected, the control module must be replaced. If control module has been opened or any attempts to repair are done, the warranty is void.

Make sure all components function properly by performing the following checks.

1. Before starting the appliance, perform a safety inspection of piping, burners and venting. Check for gas leaks, etc. Check all wiring for proper connections. Be sure the system is properly grounded, including ground connection to the burner ground (Terminal 1).
2. With the gas and thermostat off, turn on power to the appliance.
3. Turn the thermostat to a high setting and verify that the control goes through the operating sequence to a shutoff condition.
Note: The burner does not light because the gas is off.
4. Turn off the thermostat.
5. Turn on the gas and purge gas lines of all air.
6. Check for gas leaks on all pipe joints upstream of the gas valve with a soap solution.
7. Turn the thermostat to the highest setting and verify successful ignition and a normal run condition for at least 5 minutes. If the appliance fails to run, see the **Troubleshooting** section.
8. Check for gas leaks on all pipe joints downstream of the gas valve with a soap solution.
9. Turn the thermostat down for at least 30 seconds and then back up again. Verify successful ignition at least five times.
10. Return the thermostat to a normal temperature setting before leaving the installation.

Operation

Operating Mode Definitions

The following definitions describe the operating conditions.

- **Pre-Purge:** Initial time delay between the thermostat contact closure (Call for Heat) and the HSI (Hot Surface Igniter) and pilot valve are activated. The controls “LED” will flash green “ON” and “OFF” at 0.5 s rate.
- **Igniter Warmup (Timed Ignition):** The time allowed for the hot surface igniter to heat up before the Trial-For-Ignition sequence is activated. The controls “LED” will flash green “ON” and “OFF” at 0.5 s rate.
- **Trial-For-Ignition (TFI):** This is the total time the pilot valve and hot surface igniter are “ON” (energized), and flame sense sequence is activated in an attempt to light the pilot. The control attempts to prove flame within the Trial-For-Ignition time. The “LED” will flash green at 0.5 second “ON” and 0.5 second “OFF”.
- **Flame Sensed:** With a flame present, a current path is connected between the “Igniter” and “Main Burner” ground on “Internal Flame Sense” Models, or between a “Flame Sense Rod” and “Main Burner” ground on “Remote Flame Sense” Models. The “Main Burner” and gas valve remain on as long as a flame is present. When the thermostat opens (Call for Heat ends) the control turns “OFF” (de-energizes) the gas valve, thereby extinguishing the flame.
- **100% Shutoff (Flame Not Sensed) With 1 Ignition Trial (Bad Flame/No Flame):** If the control does not prove the presence of pilot burner flame within the “Trial-For-Ignition” time, then both gas valve relays are turned “OFF” (de-energized) and the control goes into Lockout mode. See Troubleshooting Guide for possible faults.

- 100% Shutoff (Flame Not Sensed) With 3 Ignition Trials (Bad Flame/No Flame):**
 If the control does not prove the presence of igniter flame within the "Trial-For-Ignition" time, then the relay gas valve is turned "OFF" (de-energized) and the control initiates a time delay of "Between-Trial-Purge" time, and then followed by another ignition sequence. If flame is not sensed, an ignition sequence is repeated until the total number of Trials-for-Ignition are completed. If flame is still not sensed then all relays are turned "OFF" (de-energized) and the control goes into lockout mode. See Troubleshooting Guide for possible faults.
- Number of Ignition Trials:** If 100% shutoff occurs and the control was set up for 3 ignition trials, the control will delay for the "Between-Trial-Purge" time and begin another Trial-For-Ignition sequence.
- Run (Operation):** Once an igniter flame is proven then the hot surface igniter is turned "OFF" (de-energized) and the gas valve is turned "ON" (energized). The gas valve remains "ON" (energized) until the thermostat is satisfied (Call for Heat).
- Flameout (Flame Lost):** After a flame is established, and a loss of proven flame occurs during burner operation the gas valve is turned "OFF" (de-energized) and the control will delay for the Between-Trial-Purge time before it begins another ignition sequence.
- Lockout:** An internal or external fault has caused the control to de-energize the hot surface igniter circuit and valve relays. The thermostat contacts must be opened for a minimum of 30 seconds and then closed to begin another ignition sequence.

Sequence of Operation

The heating cycle begins when a call for heat from the thermostat supplies 24VAC to the 24V (TH) terminal 8 on the Control which starts an ignition sequence. After a 1 second maximum diagnostic period, the prepurge cycle starts.

During the **Pre-Purge** cycle the gas valve relays and HSI (Hot Surface Igniter) remain "OFF" (de-energized). The controls "LED" will flash green "ON" and "OFF" at 0.5 s rate. At the end of the Prepurge time, the control begins the igniter warmup cycle.

Igniter Warmup (Timed Ignition) cycle turns "ON" (energizes) both HSI relays and remains on for a set time. The controls "LED" will flash green "ON" and "OFF" at 0.5 s rate. At the end of the Igniter Warmup time, the control begins the Trial-For-Ignition cycle.

Trial-For-Ignition cycle turns "ON" (energizes) the gas valve relay and the hot surface igniter remains "ON" (energized) to allow a flame to be established. The control attempts to prove flame within the Trial-For-Ignition time. The "LED" will flash green at 0.5 s "ON" and 0.5 s "OFF".

Once, a flame is detected a current path is connected between the "Igniter" and "Main Burner" ground on "Internal Flame Sense" Models, or between a "Flame Sense Rod" and "Main Burner" ground on "Remote Flame Sense" Models and the hot surface igniter is turned "OFF" (de-energized) while the gas valve remains "ON" (energized) as long as a flame is present. The control will remain in this state until the igniter flame is lost or the call for heat ends.

If igniter flame is not detected or flame lost, the gas valve is turned "OFF" (de-energized) and the controls go into 100% lockout for models having only 1 ignition trial or will restart the Ignition Sequence for Models having 3 ignition trials. The control will wait for the "Between-Purge" time while blinking the "LED" at the end of each 15 seconds during the Between-Purge cycle. When the "Between-Purge" time cycle is completed a new Ignition sequence will begin.

When the "Call for Heat" ends, the thermostat opens and the control turns "OFF" (de-energizes) the gas valve, there by extinguishing the flame.

Table 2: LED Indications during Normal Operation

Green Flash Code	Flash Code Indication
Steady On	Flame detected, Good flame, Main burner on
0.5 Second On 0.5 Second Off	Pre-purge, Between trial purge, Igniter warmup
2 Continuous Quick Flashes	Flame detected, Weak flame, Main burner on

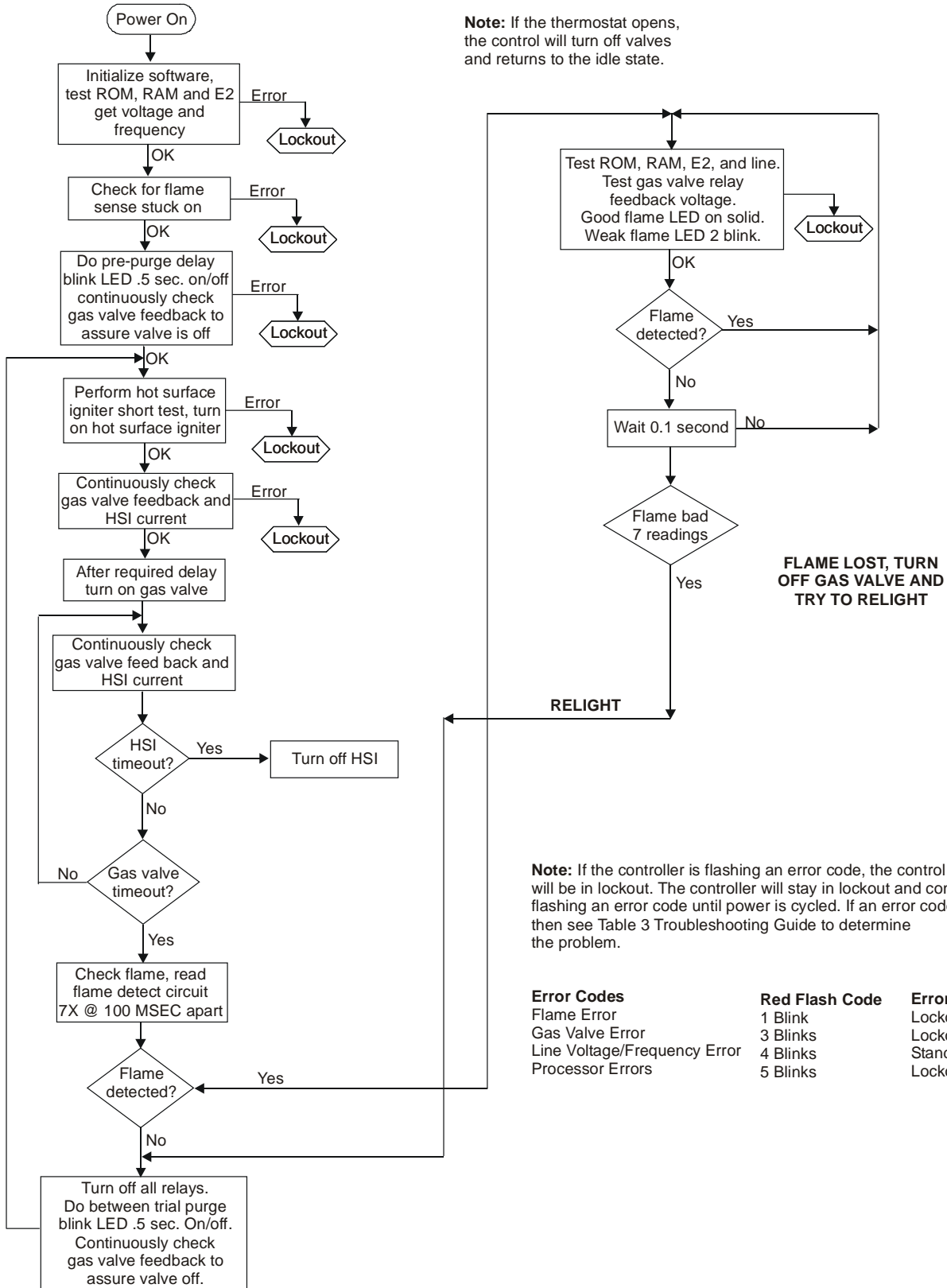

Figure 4: Sequence of Operation Flow Chart

BGH2UNCNTRLHT-01 Universal Hot Surface Ignition Control

Troubleshooting



WARNING: Risk of Personal Injury.

Do not place face, hands, or other parts of the body in or near the burner area when the LED is flashing (recycle mode). When the LED is flashing, the control may at any time (while in the recycle mode) re-energize the burner control system and ignite the burner which may result in electric shock from contact with the electrode or severe burn injury from firing of the burner.

If the system does not function properly, determine the cause using the procedures in this section.

Before proceeding with troubleshooting the system, check the following.

Preliminary Checks

- Are all mechanical and electrical connections tight?
- Is the system wired and ground correctly?
- Is gas inlet pressure per manufacturer's specifications?
- Is the system powered?
- Is the thermostat calling for heat?

LED Error Indications

If the control module internal diagnostics detect a fault it will go to lockout. The hot surface igniter and gas valve will be turned off. The LED will flash an error code 0.25 seconds "on" and 0.25 seconds "off" for each count of the error code with 1 second off between codes. The control will remain in this condition until power is removed by turning off the call for heat. The flashing LED error code indicates a problem with wiring, or a component not working, or the control module is faulty. Try to recycle the power on the control. If the error repeats then see Table 3 Troubleshooting Guide to determine the problem.

Table 3: BGH2UNCNTRLHT-01 Universal Series HSI Control Troubleshooting Guide

RED LED Flash Code	ERROR Indication	Troubleshooting Guide
No LED "ON"	No Power	<ol style="list-style-type: none"> 1. Check for 24 volts on terminal 8 (24V TH) and terminal 2 (24V GND). 2. Check for "OPEN" limits wired between terminal 8 (24V TH) and the 24 volt secondary coil winding of the controls transformer. 3. Check for 24 volts on the secondary coil winding of the controls transformer.
1	Flame Sense Circuit	<ol style="list-style-type: none"> 1. Check if gas is turned "ON". 2. Check incoming power (NEUTRAL) wiring to terminal 4 (L2 NEUTRAL). 3. Check Igniter wiring to terminal 7 (HSI HOT) and terminal 5 (HSI NEUTRAL). 4. Check Flame Sensor tip is in the flame. For proper sensing the rod tip must be 3/8" (10mm) to 1/2" (13mm) in the flame. 5. Check the Burner Ground is in the pilot flame. For proper sensing, the burner ground must be 3/8" (10 mm) to 1/2" (13 mm) in the flame and is connected to terminal 1 (BURNER GND). 6. For Internal Flame Sense circuits, check "JUMPER WIRE" is on terminal 10 (SENSE REMOTE) and terminal 7 (HSI HOT). 7. For a Remote Flame Sense circuit; check that the Jumper Wire is removed from Terminal 10 (SENSE REMOTE) and Terminal 7 (HSI HOT). Also, check wiring of the Remote Flame Sensor the Terminal 10 (SENSE REMOTE).
3	GAS Valve Circuit	<ol style="list-style-type: none"> 1. Check "GAS VALVE" wiring to terminal 9 (VALVE) and terminal 3 (VALVE GND). 2. Check for 24 volts at the coil of the "GAS VALVE".
4	Line Voltage /Freq. Circuit	<ol style="list-style-type: none"> 1. Check Burner Ground wiring to terminal 1 (BURNER GND). 2. Check incoming power Line 1 (HOT) (120 or 240 VAC) wiring to terminal 6(L1 HOT).
5	Internal Control	<ol style="list-style-type: none"> 1. Review all ground connections. 2. Software error – Restart control module.

NOTE: If Troubleshooting Guide has been used, and the Control Module is flashing a RED LED FLASH ERROR CODE, then the Control Module may be faulty. Replace the Control Module.

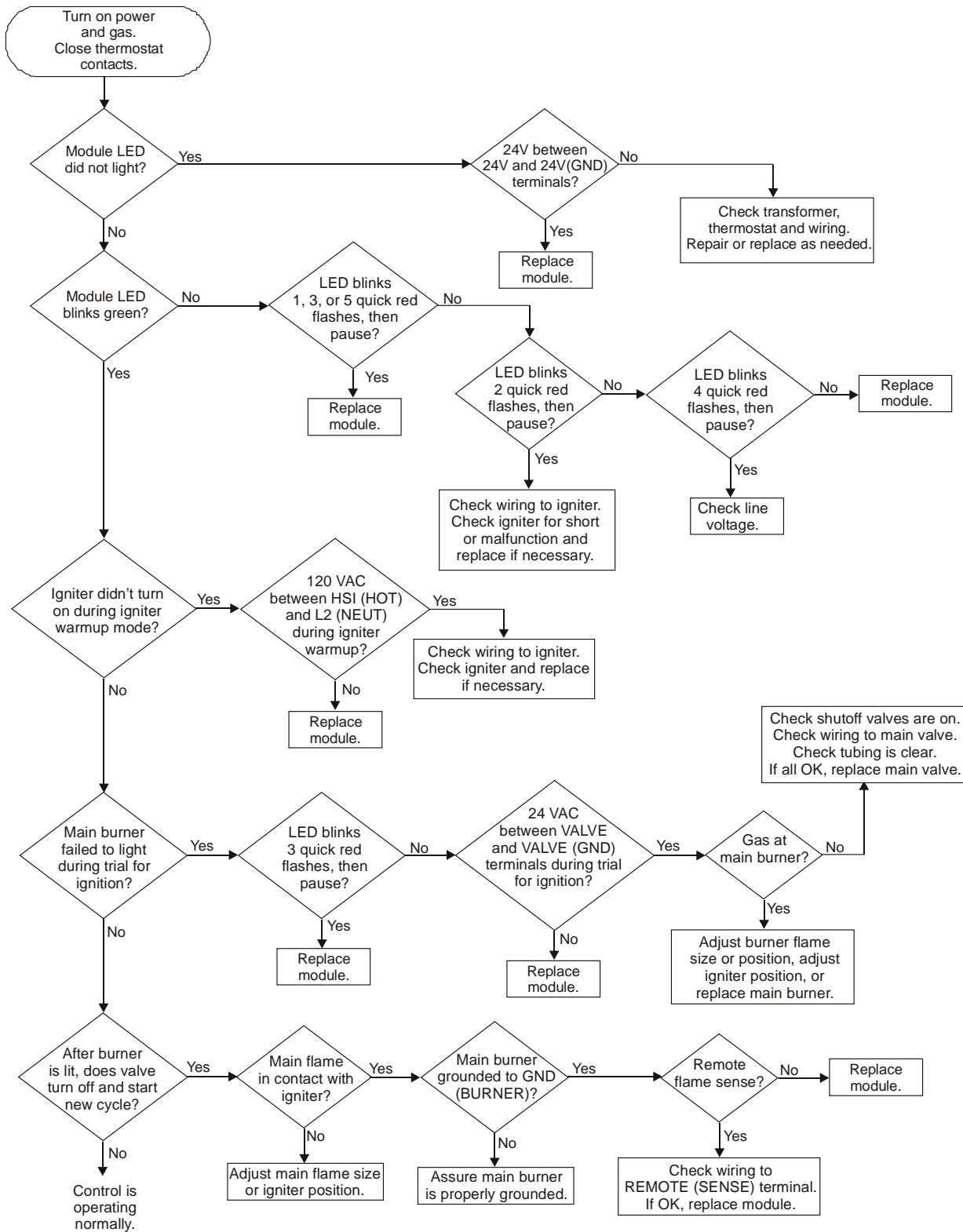

Figure 5: BGH Universal Series HSI (Hot Surface Ignition) Control Troubleshooting Flowchart

Maintenance Requirements in Severe Environments

Regular preventive maintenance is important in any application, but especially so in commercial cooking, agricultural, and industrial applications because:

- In many such applications, particularly commercial cooking, the equipment operates 100,000 to 200,000 cycles per year. Such heavy cycling can wear out the gas control in one to two years. A normal forced air furnace, for which the controls were originally intended, typically operates less than 20,000 cycles per year.
- Exposure to water, dirt, chemicals, and heat can damage the ignition control module or the gas control and shut down the control system. A NEMA 4 enclosure can reduce exposure to environmental contaminants.



WARNING: Risk of Explosion or Fire. Do not attempt to take the ignition control module apart or to clean it. Improper reassembly and cleaning may cause unreliable operation, which can lead to an explosion or fire, and may result in severe injury, property damage or death.

Maintenance frequency must be determined individually for each application. Some considerations are:

- **Cycling Frequency** – Appliances that may cycle more than 20,000 times annually should be checked monthly.
- **Intermittent Use** – Appliances that are used seasonally should be checked before shutdown and again before the next use.
- **Consequence of Unexpected Shutdown** – Where the cost of an unexpected shutdown would be high, the system should be checked more often.
- **Dust, Wet, or Corrosive Environment** – Since these environments can cause the controls to deteriorate more rapidly, the system should be checked more often.

Repairs and Replacement



CAUTION: Risk of Electric Shock.
Disconnect power supply before making electrical connections to avoid electric shock.



WARNING: Risk of Explosion or Fire.
Shut off the gas supply at the main manual shutoff valve before installing or servicing the control. Failure to shut off the gas supply can result in the release of gas during installation or servicing, which can lead to an explosion or fire, and may result in severe injury or death.



WARNING: Risk of Explosion, Fire, or Electric Shock. Label all wires before they are disconnected when replacing or servicing the BGH2UNCNTRLHT-01. Wiring errors can cause improper or dangerous operation and may result in an explosion, fire, or electric shock leading to severe personal injury or death.

Field repairs must not be made to the control. Any attempt to repair this assembly voids the manufacturer's warranty. For a replacement control, contact the original equipment manufacturer or the nearest BASO Gas Products distributor.

All other accessories, such as flame sensors, electrode assemblies, pilot assemblies, and leads can be obtained through the original equipment manufacturer or a BASO Gas Products distributor.

Cut out and leave near control.

Green LED Indications During Normal Operation		
Steady On	Flame detected, Good flame, Main burner on	
0.5 Second On, 0.5 Second Off	Pre-purge, Between trial purge, Igniter warmup	
2 Continuous Quick Flashes	Flame detected, Weak flame, Main burner on	
Red LED Indications During Error Operation		
1 Flash, then pause	Flame Error	Lockout
3 Flashes, then pause	Gas Valve Error	Lockout
4 Flashes, then pause	Line Voltage/Frequency Error	Standby
5 Flashes, then pause	Internal Control Error	Lockout

Notes

Notes

Notes

Technical Specification

Product	BGH2UNCNTRLHT-01 Universal Hot Surface Ignition Control
Ignition Type	Hot Surface Ignition (HSI)
Ignition Source	High voltage (120/240VAC) HSI (Hot Surface Igniter)
Flame Sense Cable Maximum Length	48 in. (1,220 mm)
Flame Detection Means	Flame Rectification
Flame Detection Type	Internal or Remote
Flame Failure Response Time	2.0 seconds maximum
Warmup Time (Timed Ignition)	17, 34, or 45 seconds
Pre-Purge Time	None, 17, 30, or 32 seconds
Between Trial Purge Time	None, 60,77,90 or 96 seconds
Ignition-Trial-Time (Before Lockout)	4 or 7 seconds
Number of Trials (Before 100% Shutoff)	1 or 3
Power Requirements	Control: 24 VAC (+/- 20%), 50/60 Hz. Operating Current: 0.2 A nominal + valves
Gas Valve Relay Contact Rating	2 A maximum @ 24 VAC
Hot Surface Ignition Relay Contact Rating	3 A maximum @ 240 VAC 6 A maximum @ 120 VAC
Wiring Connections	1/4 in. (6.35 mm) male spade
Maximum Firing Rate	400,000 Btu/hr (117 kW)
Ambient Operating and Storage Temperature	-40 to 175°F (-40 to 79°C)
Humidity	95% RH non-condensing
Type of Gas	Natural, Liquefied Petroleum (LP), Manufactured, Mixed or LP Gas-Air Mixture
Packaging	Bulk pack supplied to original equipment manufacturer (individual pack [-1AAC] or individual overpack [-1AAE, 20 per box] optional)
Bulk Pack Quantity	25
Pack Weight	Bulk pack (-1AAD) 14 lb (6.36 kg) Individual pack (-1AAC) 1 lb (.454 kg) Individual overpack (-1AAE) 18 lb (8.17 kg)
Agency Listing	CSA Certificate Number 246569-2213607
Specifications Standards	ANSI Standard Z21.20 CAN/CSA-C22.2 No. 199

The performance specifications are nominal and conform to acceptable industry standards. All agency certification of BASO products is performed under dry and controlled indoor environmental conditions. Use of BASO products beyond these conditions is not recommended and may void the warranty. If the product is exposed to water (dripping, spraying, rain, etc.) or other harsh environments, it must be protected. The original equipment manufacturer or end user is responsible for the correct application of BASO products. For questionable applications, please consult BASO Gas Products LLC. BASO Gas Products LLC shall not be liable for damages or product malfunctions resulting from misapplication or misuse of its products.

450 East Horseshoe Road
PO Box 170
Watertown, WI 53094
1-877-227-6427 (1-877-BASOGAS)

www.baso.gas
Published in U.S.A.

BGH2UNCNTRLHT-01 Universal Hot Surface Ignition Control