



## H19 Series BASO High Pressure Safety Pilot Valves

*The H19 Series BASO high pressure safety pilot valves are designed for commercial and industrial applications with gas pressures of up to and including 25 psi (1.72 bar [172 kPa]). The H19TB high temperature model is available for gas pressures at 15 psi (1.03 bar [103 kPa]). Applications include industrial heaters, crop dryers and similar appliances.*



Figure 1: H19 High Pressure Safety Pilot Valve

Features and Benefits	
<input type="checkbox"/> <b>Compact Design</b>	Permits installation in dimensionally restricted applications
<input type="checkbox"/> <b>Safe Lighting</b>	Allows gas flow only to the pilot burner during lighting on models with flow interruption
<input type="checkbox"/> <b>Reliable</b>	Proven by thousands of units in service

## Product Overview

### Application

The H19 Series BASO high pressure safety pilot valves provide safe lighting and complete shutoff of pilot and main burner gas. They are suitable for use with natural gas, Liquefied Petroleum (LP) gas or LP gas-air mixtures, at pressures up to 25 psi (1.72 bar [172 kPa]). The H19 is also suitable for operation over a temperature range of -40 to 150°F (-40 to 66°C). The H19TB is suitable for operating pressures of 15 psi (1.03 bar [103 kPa]) and temperatures range of -40 to 225°F (-40 to 107°C).

**IMPORTANT:** Care should be taken to ensure the valve is installed in applications where operating pressures in excess of 25 psi (1.72 bar [172 kPa]) are not expected to develop.

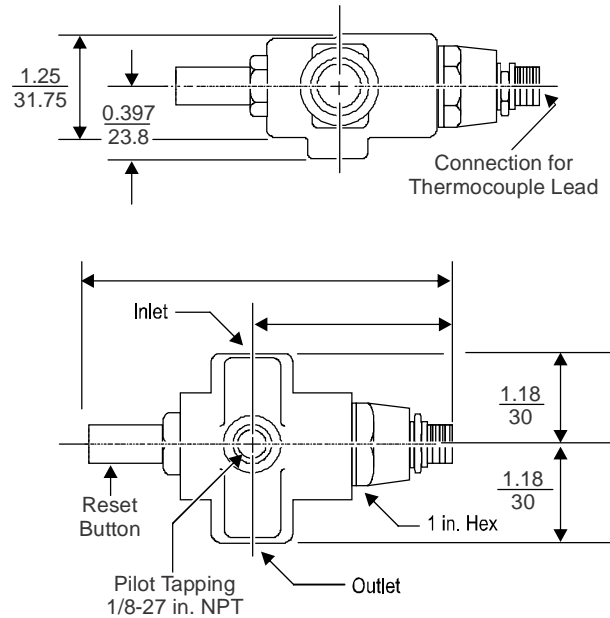
### Description

H19 valves are 100% shutoff devices with compact, cast aluminum valve bodies. When lighting the pilot burner, the reset button must be depressed. On models with flow interruption feature, gas flows only to the pilot during lighting operation. Models without flow interruption permit gas to flow to both the pilot and main burner.

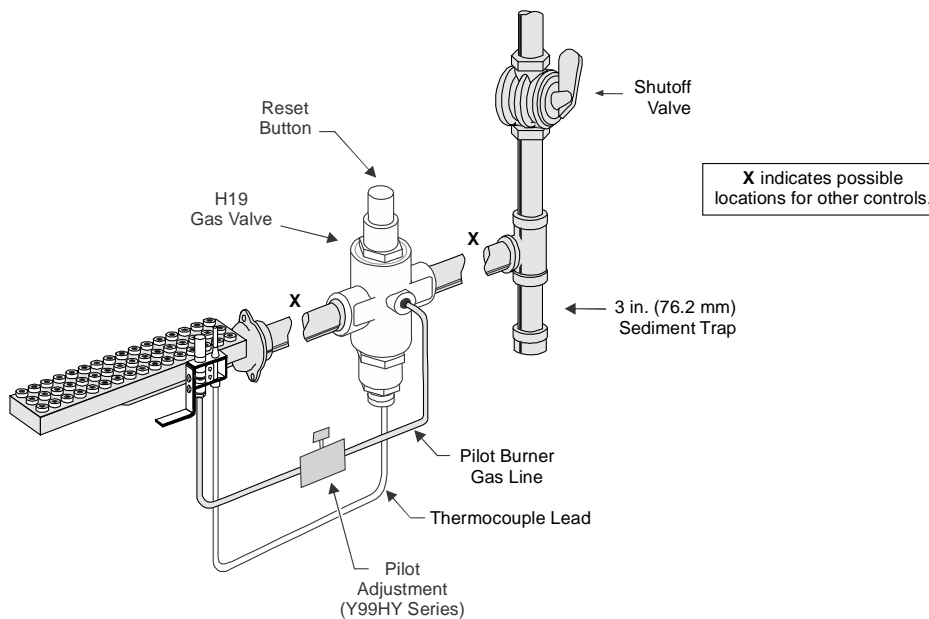
### Mounting

H19 valves may be mounted in any position. This permits the reset button to be located in the most accessible location. See Figure 3.

### Dimensions

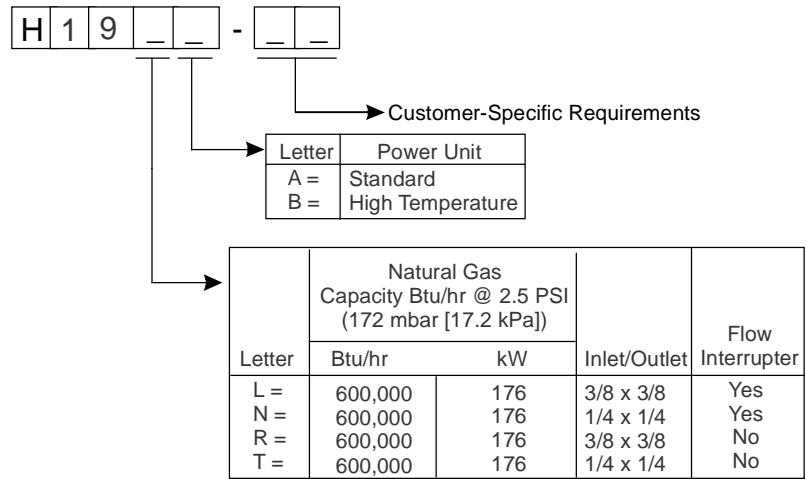


**Figure 2: Dimensions, in. (mm)**



**Figure 3: Typical Installation**

## Ordering Information



Note: The presence of a particular construction in this information does not guarantee its availability. Consult BASO Gas Products for available constructions.

**Figure 4: Ordering Matrix**

## Technical Specifications

<b>Product</b>	H19 BASO High Pressure Safety Pilot Valves
<b>Rated Inlet Pressure</b>	25 psi (1.72 bar [172 kPa]) 15 psi (1.03 bar [103 kPa]) H19TB only
<b>Valve Body</b>	Aluminum
<b>Recommended Thermocouple Lead Lengths</b>	K15: 12 to 48 in. (305 to 1,220 mm) K16: 12 to 72 in. (305 to 1,830 mm) K19: 18 to 72 in. (457 to 1,830 mm)
<b>Ambient Temperature</b>	-40 to 150°F (-40 to 66°C) -40 to 255°F (-40 to 107°C) H19TB only
<b>Inlet and Outlet Body Connections</b>	1/4 or 3/8 in. NPT (25 psi valves) 1/4 in. NPT (H19TB 15 psi valve)
<b>Types of Gas</b>	Natural, Liquefied Petroleum (LP) or LP gas-air mixtures
<b>Packaging</b>	Bulk pack supplied to original equipment manufacturer (individual pack optional)
<b>Bulk Pack Quantity</b>	60
<b>Bulk Pack Weight</b>	30 lb (14 kg)
<b>Agency Listing</b>	CSA Certificate Number 229521-1656106 Australian Gas Association Certificate Number 6734 AGA Class 3, Valve Type Safeguard (excludes H19TB) UL Recognized File Number MH2926 (excludes H19TB)
<b>Specification Standards</b>	ANSI Z21.20, CAN1-6.4 ANSI Z21.21, CSA 6.5 AS 4620 UL Standard 372

*Performance specifications are nominal and conform to acceptable industry standards. All agency certification of BASO products is performed under dry and controlled indoor environmental conditions. Use of BASO products beyond these conditions is not recommended and may void the warranty. Product must be protected if exposed to water (dripping, spraying, rain, etc.) or other harsh environments. The original equipment manufacturer or end user is responsible for the correct application of BASO products. Consult BASO Gas Products LLC for questionable applications. BASO Gas Products LLC shall not be liable for damages or product malfunctions resulting from misapplication or misuse of its products.*

Refer to the *H19 Series BASO High Pressure Safety Pilot Valves Installation Instructions* (BASO-INS-H19HP) for necessary information on the installation, use, and servicing of this product.



BASO Gas Products LLC

1007 South 12th Street  
PO Box 170  
Watertown, WI 53094  
1-877-227-6427 (1-877-BASOGAS)

[www.baso.com](http://www.baso.com)  
Printed in U.S.A.