



24 VAC Universal Direct Spark Gas Ignition Control

Quick Reference Guide

The C107U Universal Direct Spark Ignition Control module replaces many popular flame rectification type of direct spark ignition (DSI) modules, including those manufactured by Honeywell, Robert Shaw, ICM, Fenwal, and Johnson Controls.

The following is an overview of the C107U series control, and is intended to only be used by Certified Service Technicians.

APPLICATION

- Gas Furnaces
- Boilers
- Water Heaters
- Commercial Cooking

FEATURES

- 24 VAC microprocessor based DSI control
- System diagnostics
- 32 Selectable preset timings of popular models
- Universal flame sensing (Local/Internal or Remote/External)
- Full time flame sensing
- Flame sense test pins
- 4 mounting hole positions, 2 that match Honeywell and Fenwal
- Built-in burner ground
- Voltage/Frequency monitoring



SPECIFICATIONS

Input Voltage	Control: 24 VAC (18-30 VAC) 50/60 Hz
Input Current	0.3 A nominal + valves
Gas Valve Contact Rating	4A Main @ 24 VAC
Alarm Output	2QA @ 24 VAC
Operating Temperature	-40 to 176°F (-40 to 80°C)
Flame Detection Means	Flame Rectification
Flame Detection Type	Local/Internal or Remote/External
Minimum Flame Current	0.07 microamperes
Flame Failure Response Time	1.0 second maximum
Ignition Source	High voltage spark, capacitive discharge
Maximum Spark Gap	0.2 in. (5.1 mm)
High Voltage Cable	48 in. (1219 mm) max., rated 15kV min. (Resistive recommended)
Flame Sense Cable	48 in. (1219 mm) max., rated 15kV min. (Shielded recommended)
Spark	30 sparks/second
Humidity	0% to 95% RH (non-condensing)
Gas Types	Natural, LP, or Manufactured
Trials Before Lockout *	Default, 1, or 3
Trial for Ignition (TFI) Time*	Default, 4, 7, 11, or 21 seconds
Pre-Purge Time *	Default, 0, or 30 seconds
Inter-Purge Time *	Default, 0, 15, 30, or 90 seconds
Retry Delay Period *, **	Default, 0, 5*, or 60* minutes
Lockout Recovery	Power cycle

*32 Selectable preset timings via. 5 position DIP Switch.

**Retry is not available in CE ignitions.

Agency Certifications



UL 60370-1, UL 60730-2-5

File: M2926 Software conforms to UL60730 Requirement Component Recognized System (US & Canada)



EN298:2012

File: 657989

24 VAC Universa Direct Spark Gas Ignition Control

WIRING

TABLE 1: Typical Wiring Connections.

Label	Term. Type	Description
FC - +	2-pin	Flame Current measuring for microammeter probes in μ Amp DC
BRN GND	Mounting Tab (Lower left)	Burner Ground connection*
24V GND BRN GND	1/4" male QC	Common side (return) of transformer connection
VLV COM	1/4" male QC	Gas Valve common terminal
VLV	1/4" male QC	Gas Valve connection
ALM	N/A	Not Available
TH-W	N/A	Thermostat connection
R/O	N/A	Rollout Switch connection
24V	1/4" male QC	24V Power connection
DIP SWITCH S1	5 position DIP switch	32 selectable timings of the most popular settings
SENSE	1/4" male QC	Flame Sensor connection - For dual rod (remote/external) flame sensing, remove Jumper Wire installed and connect flame sense wire from the burner/igniter to this terminal - For single rod (local/internal) sensing leave Jumper Wire connected to the INT connector
INT	1/4" male QC	- For single rod (local/internal) sensing a Jumper Wire is connected to the SENSE connector NOTE: Remove and discard Jumper Wire for two rod (remote/external) flame sensing
SPARK	1/4" male QC	High voltage sparking electrode

* If the existing system uses a burner ground wire, this can be attached to the 24V GND/BRN GND terminal using the supplied dual spade connector, or otherwise connected to the burner ground mounting tab.

SETUP AND ADJUSTMENTS

DIP Switch (S1) Settings

When replacing an existing ignition control with the C107U, refer to Table 2 for the correct DIP switch settings. For a complete list of the controls the C107U replaces, see the BASO C107U Installation Instructions available at www.baso.com.

The following timing parameters may be set with the 5-position DIP switch (see Table 2).

IMPORTANT:

The control timing configuration is *permanently* locked and cannot be reset by changing the DIP switch settings after **10 consecutive power cycles**.

FACTORY DEFAULT S1 DIP SWITCH SETTING

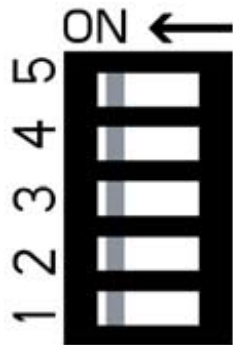

All switch settings are defaulted from the factory to the “ON” position. Refer to Table 2 for the desired timing configuration. The default timings are printed on the label located on the front of the ignition.

TIMING CONFIGURATION LABEL

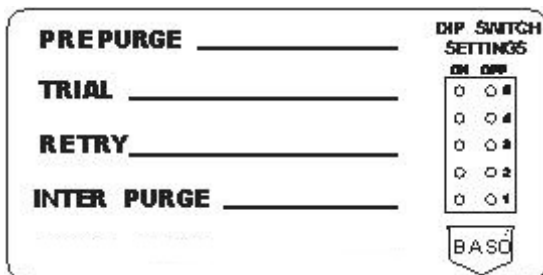

Once you have selected the desired timing configuration, using a permanent marker, write in the values and mark the DIP switch settings on the label provided. Adhere the label to the front of the control for future reference.

Note: After the configured number of trials for ignition with no established flame or the pre-defined number of flame losses have occurred, controls with a retry time of 0 (i.e. none) will enter a 100% Lockout mode, requiring the pre-defined lockout recovery method (power cycle) to continue normal operation. However, controls with a retry time of 5 or 60 minutes will enter a standby lockout mode for the configured time before continuing to normal operation.

Table 2 DIP Switch (S1) Settings.

SEL	Timing Configurations					DIP (S1) Switch Settings				
	# of Trials	Pre-Purge	TFI	Inter-Purge	Retry Time	SW	SW	SW	SW	SW
	#	sec	sec	sec	min	1	2	3	4	5
0	1	0	4	0	5	OFF	OFF	OFF	OFF	OFF
1	1	30	4	0	5	OFF	OFF	OFF	OFF	ON
2	1	0	7	0	5	OFF	OFF	OFF	ON	OFF
3	1	30	7	0	5	OFF	OFF	OFF	ON	ON
4	1	0	11	0	5	OFF	OFF	ON	OFF	OFF
5	1	30	11	0	5	OFF	OFF	ON	OFF	ON
6	3	0	4	30	5	OFF	OFF	ON	ON	OFF
7	3	0	4	90	5	OFF	OFF	ON	ON	ON
8	3	30	4	90	5	OFF	ON	OFF	OFF	OFF
9	3	30	7	30	5	OFF	ON	OFF	OFF	ON
10	3	0	7	90	5	OFF	ON	OFF	ON	OFF
11	3	30	7	90	5	OFF	ON	OFF	ON	ON
12	3	0	11	15	5	OFF	ON	ON	OFF	OFF
13	3	30	21	15	5	OFF	ON	ON	OFF	ON
14	3	30	21	30	5	OFF	ON	ON	ON	OFF
15	3	0	11	15	60	OFF	ON	ON	ON	ON
16*	1	0	4	0	0	ON	OFF	OFF	OFF	OFF
17*	1	30	4	0	0	ON	OFF	OFF	OFF	ON
18*	1	0	6	0	0	ON	OFF	OFF	ON	OFF
19*	1	30	6	0	0	ON	OFF	OFF	ON	ON
20*	1	0	7	0	0	ON	OFF	ON	OFF	OFF
21*	1	30	7	0	0	ON	OFF	ON	OFF	ON
22*	1	30	11	0	0	ON	OFF	ON	ON	OFF
23*	1	0	21	0	0	ON	OFF	ON	ON	ON
24*	1	30	21	0	0	ON	ON	OFF	OFF	OFF
25*	3	15	4	15	0	ON	ON	OFF	OFF	ON
26*	3	30	4	15	0	ON	ON	OFF	ON	OFF
27*	3	0	7	15	0	ON	ON	OFF	ON	ON
28*	3	30	7	15	0	ON	ON	ON	OFF	OFF
29*	3	0	11	15	0	ON	ON	ON	OFF	ON
30*	3	30	11	15	0	ON	ON	ON	ON	OFF
31*	-	-	-	-	-	ON	ON	ON	ON	ON

* Approved CE timing configurations.

NOTE: All controls have Quick Start and Re-ignition.

LED STATUS AND TROUBLESHOOTING

The ignition control has a multi-colored (GREEN, ORANGE, and RED) LED which will flash different colors and codes to show status of the ignition and will help troubleshoot the control.

Table 3: GREEN LED Indications of Normal Operation

Flash	Indication
1 flash every 1 sec.	Pre-purge, Inter-purge
Rapid flashing	Trial for Ignition (TFI)
Solid on	RUN (Flame, Main valve on)

Table 4: ORANGE LED Indications

Flash	Indication	Error Type
1 flash every 5 sec.	Retry	Standby
1 flash every 1 sec.	Flame Present	Standby

Table 5: RED LED Indications of ERROR Codes (100% Lockout)

Flash	Indication	Error Type
1 flash	No flame in trial time	100% Lockout
2 flashes	Flame sense stuck	100% Lockout
3 flashes	Valve relay circuit	100% Lockout
7 flashes	Repetitive flame loss	100% Lockout
8 or 9 flashes	Internal control	100% Lockout
Solid on	Line voltage/Frequency	Standby

Note: There is a one-second pause after each flash code.

Warning: Do not install the control in areas that can be exposed to dripping water, steam cleaning, heavy dust, grease, or corrosive chemicals. If the controls can be subjected to this type of environment, use a NEMA 4 rated enclosure to protect the ignition control module.

If not properly protected from the above environment, the control will prematurely fail or malfunction. Excessive high temperatures can damage the ignition control and cause it to malfunction. Make sure the ambient temperature around the ignition does not exceed the rated temperature for the control.

TROUBLESHOOTING GUIDE

1. No power up
 - Faulty 24 VAC wiring
 - Thermostat or transformer
 - Faulty control
 - Safety limits
2. Control LED is blinking RED
 - Determine error code, refer to error codes (Table 5), also refer to the troubleshooting flow chart in the installation instructions
3. No spark during Trial for Ignition (TFI) time
 - Faulty spark electrode wiring
 - Spark gap too wide
 - Faulty control
4. Burner does not light during trial for ignition time
 - Faulty valve wiring
 - Bad Gas Valve
 - Faulty Control
5. Burner lights but gas valve turns off after TFI
 - Weak flame, flame not in contact with the spark electrode of flame sensor. Check that flame sensor tip is in the flame. For proper sensing, the rod tip must be $3/8"$ (10mm) to $1/2"$ (13mm) in the flame. See Figure 1.
 - Dirty or corroded flame sensor
 - Faulty flame sensor wiring
 - Poor burner ground

Note: For more information on BASO ignitions and other products, plus complete installation instructions, please visit us at www.baso.com.

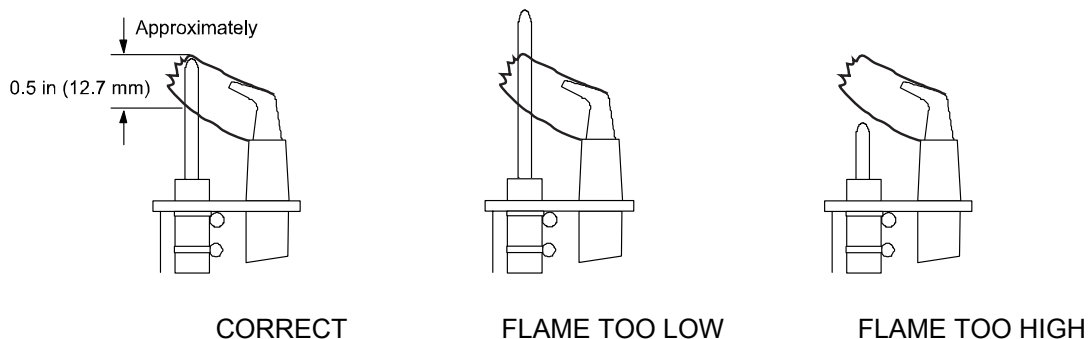

Figure 1: Proper Flame Sensor Position

24 VAC Universal Direct Spark Gas Ignition Control

FLAME CURRENT MEASUREMENT

Flame current of the device can be measured using a standard microammeter by simply touching the meter leads to the 2 PIN labeled FC, as shown in Figure 2.

- Flame current must be measured with flame lit and main gas flowing
- Set meter to DC μ Amp scale.
- Make sure meter leads are positioned correctly [+/-].
- Typical Flame Sense Current of 0.4 to 1.0 μ Amp DC.

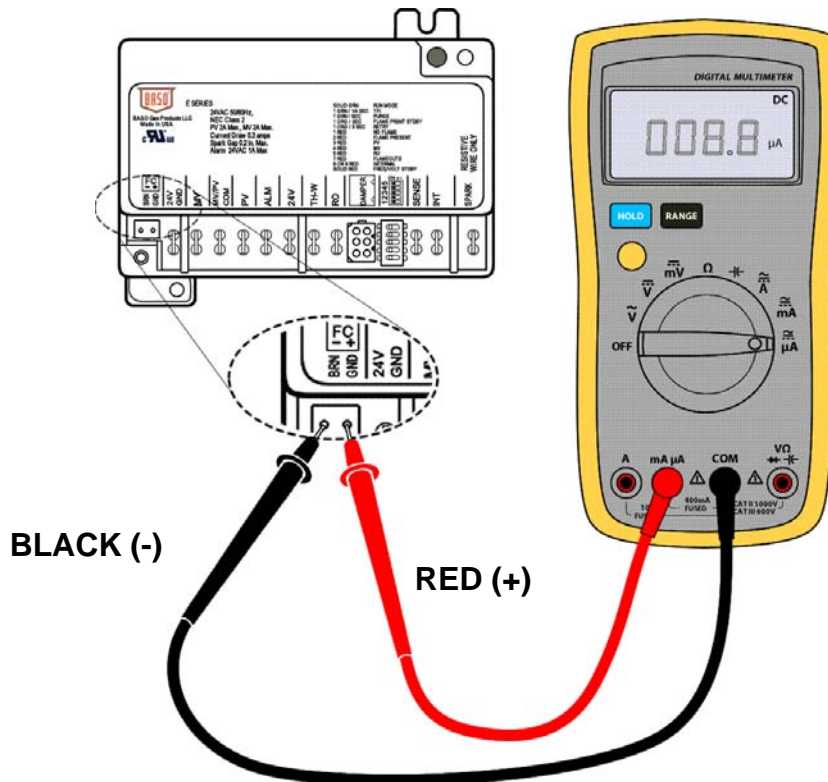

Figure 2: Microammeter Connection.

Important: Preventative maintenance programs are an important part of maintaining optimum and safe function of you BASO Products. Any attempt to repair this assembly voids the manufacturer's 2-year warranty. For a replacement control, contact the original equipment manufacturer or nearest BASO Gas Products distributor.

450 East Horseshoe Road
PO Box 170
Watertown, WI 53094
1-877-227-6427 (1-877-BASOGAS)

www.baso.com
Published in U.S.A.

24 VAC Universa Direct Spark Gas Ignition Control

© 2019 BASO Gas Products
Part No. BASO-INS-C107UQRG, Rev. C

8
www.baso.com