



# G195 Model Rev. B Series BASOTROL Combination Gas Valve with Manual Shutoff Valve

## Application

The G195 valves are suitable for use with natural gas, Liquefied Petroleum (LP) gas, or LP gas-air mixtures. Typical applications include electronic ignition systems on residential furnaces, boilers, unit heaters, rooftop equipment, agricultural heaters, commercial cooking equipment, and other types of light commercial and residential heating units.

## Installation

**IMPORTANT:** Only qualified personnel should install or service BASO® Gas Products products. These instructions are a guide for such personnel. Carefully follow all instructions in this document and all instructions for the appliance.

**IMPORTANT:** Make all gas installations in accordance with applicable local, national, and regional regulations.

 **CAUTION: Risk of Electric Shock.** Disconnect power supply before making electrical connections to avoid electric shock.

 **WARNING: Risk of Explosion or Fire.** Shut off the gas supply at the main manual shutoff valve before installing or servicing the G195. Failure to shut off the gas supply can result in the release of gas during installation or servicing, which can lead to an explosion or fire, and may result in severe personal injury or death.

 **WARNING Risk of Explosion, Fire, or Electric Shock.** Label all wires before they are disconnected when replacing or servicing the G195. Wiring errors can cause improper or dangerous operation and may result in an explosion, fire, or electric shock leading to severe personal injury or death.

**IMPORTANT:** Verify that the valve is installed only in applications where the specified maximum ambient (surface) temperature and maximum operating pressures do not exceed the limits in the *Technical Specifications* section.

To install the G195 valve:

1. Shut off power to the appliance.
2. Shut off the gas at the main manual shutoff valve.
3. Label each wire with the correct terminal designation prior to disconnection.
4. Compare the voltage on the valve with the power source voltage to ensure the correct unit is being installed. For valves with 25-volt coils, use a National Electrical Code (NEC) Class 2 transformer.  
**Note:** The transformer must be mounted to a grounded metal enclosure.
5. Ensure that the gas flows through the valve body in the direction indicated by the arrow on the valve body. If the valve is installed with the gas flow in the opposite direction of the arrow, leakage can occur.

**IMPORTANT:** Do not use a wrench on any surface other than the casting flats provided at the inlet and outlet ends of the valve body. The G195 may be damaged in the mounting process if a wrench is used on any other surface. Using a wrench incorrectly may void the warranty.

6. Mount the G195 on a horizontal manifold with the solenoid pointed up (vertical) or in a position not exceeding 90° from vertical. The valve may also be mounted on a vertical manifold in any position around its axis (Figure 1).

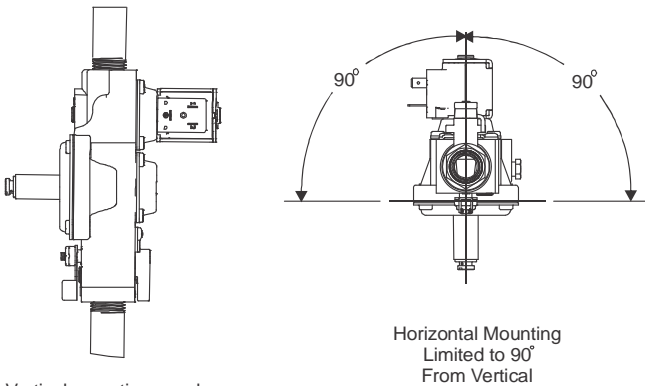

Vertical mounting may be 360° around its axis with the flow either up or down, but always in the direction of the arrow.

**Figure 1: G195 Mounting Positions**

6-7. Mount the valve to the pipework. Use an approved pipe joint sealing compound on the male threads before assembly. Remove excess compound after mounting the valve to the pipework. Threads of the pipe and nipples must be smooth and free of tears and burrs. Steam clean all piping to remove foreign substances such as cutting oil or thread chips. A sediment trap should also be installed in accordance with the National Fuel Gas Code (ANSI Z223.1). See Figure 2.

8. Thread pipe (the amount shown in Table 1) for insertion into the control. Do not thread the pipe too far. Valve distortion or malfunction may result if the pipe is inserted too deeply.

**Table 1: NPT Pipe Thread Length into Valve**

Pipe Size (NPT)	Thread Pipe Amount (in.)	Maximum Depth Pipe (in.)
1/2	3/4	1/2
3/4	13/16	3/4

9. For any threaded connections, threads of pipe and nipples must be smooth and free of tears and burrs. Steam clean all piping inside diameter to remove foreign substances such as cutting oil or thread chips before installing into the valve. Apply a moderate amount of good quality pipe compound (do not use Teflon tape) to pipe only, leaving two end threads bare (see Figure 1). On LP installations, use compound resistant to LP gas.

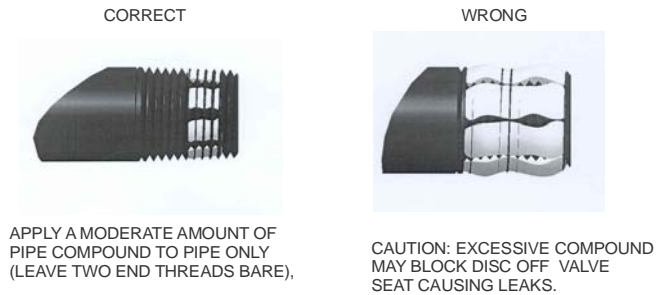

**Figure 2: Use a Moderate Amount of Pipe Compound**

10. Connect pipe to gas control inlet and outlet. Use a wrench on the square ends of the control. If a wrench is used, place the wrench on the flange rather than on the control. this process should be used for both the installation and removal of the valve in the gas system (see Figure 3).

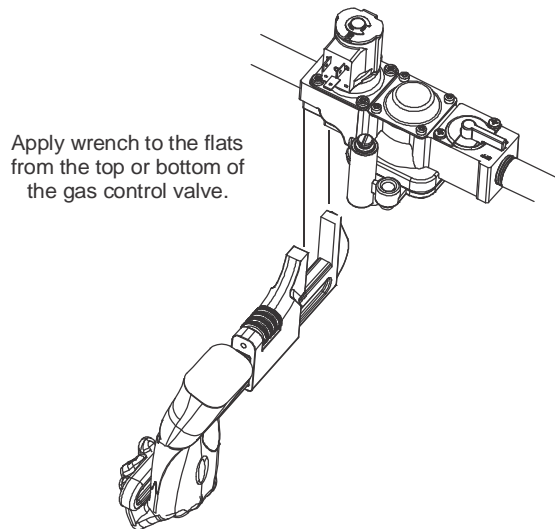

**Figure 3: Proper Use of Wrench on Gas Control**

**DO NOT USE THE SOLENOIDS FOR LEVERAGE**

11. Attach the pilot gas line to the pilot burner fitting and to the pilot gas outlet of the valve (if used).



**WARNING: Risk of Explosion or Fire.**  
Verify that there are no gas leaks by testing with appropriate equipment. Never use a match or lighter to test for the presence of gas. Failure to test properly can lead to an explosion or fire and may result in severe personal injury or death.

12. Check for leakage.
  - a. Shut off the gas at the main manual shutoff valve and open the pressure connection between the manual shutoff valve and the G195 valve.
  - b. Connect air tubing with a maximum pressure of 1-1/2 times the valve's maximum operating pressure (as indicated on the valve) to the opened pressure connection.
  - c. Paint all valve body connections with a rich soap and water solution.

If bubbles occur, this is an indication of a leak. To stop a leak, tighten joints and connections. Replace the part if the leak cannot be stopped.

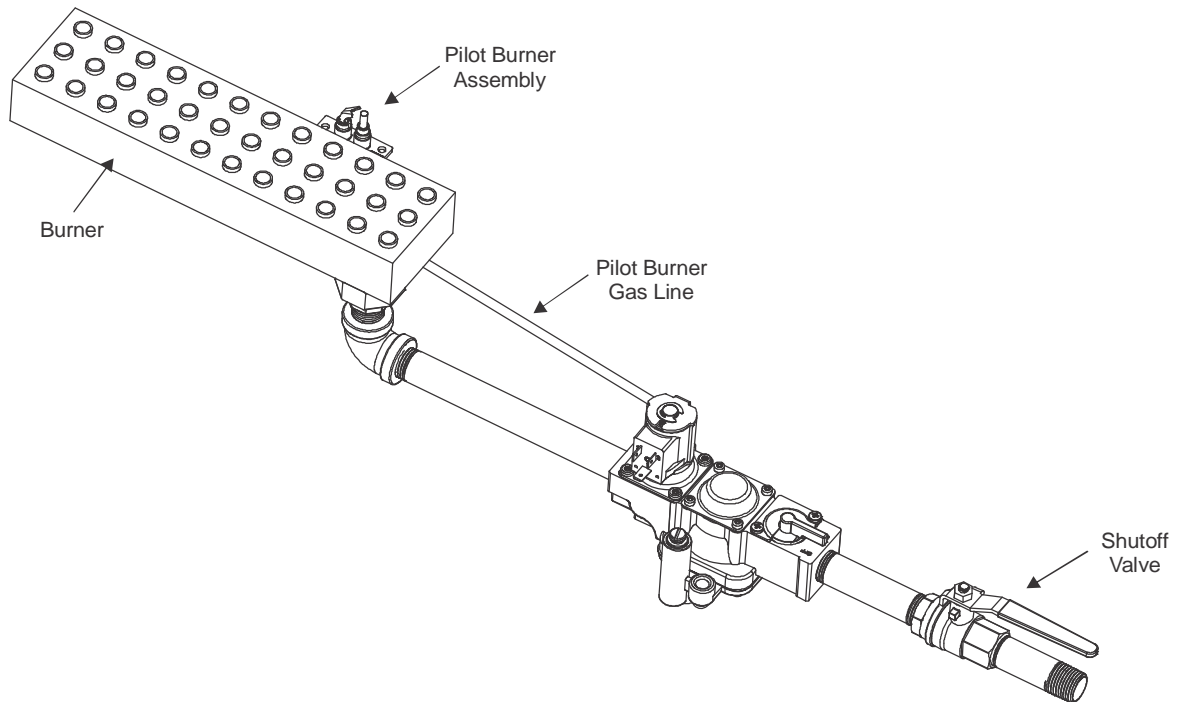

**Figure 6: Typical G195 Gas Valve Installation**

If bubbles do not occur, remove the air tubing and close the pressure connection.

13. Perform the *Checkout* section before leaving the installation.

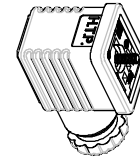

**Figure 4: SVC200 Wire Connect DIN Type Connector**

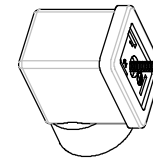

**Figure 5: SVC210 Conduit 1/2 NPT DIN Type Connector**  
**DO NOT USE THE SOLENOIDS FOR LEVERAGE**

## Setup and Adjustments

### Checkout



#### **WARNING: Risk of Explosion or Fire.**

Follow this or an equivalent checkout procedure after installation. Before leaving the installation, verify that the gas valve functions properly and that the system has no gas leaks. Gas leaks can lead to an explosion or fire, and may result in severe personal injury or death.

Make sure all components are functioning properly by performing the following test.

1. Test all joints and connections for leaks with a soap solution.
2. Close the main upstream shutoff valve and wait at least 5 minutes for unburned gas to escape from the appliance, and then reopen the valves.
3. Turn on the main electrical power switch and close the thermostat contacts. The appliance should operate in accordance with the manufacturer's specified sequence of operation.
4. Turn the thermostat to a low dial setting to open the contacts. All burner flames should be extinguished. Repeat Steps 3 and 4 at least three times.
5. Return the thermostat to a normal setting before leaving the installation.

### Regulator Adjustment



#### **WARNING: Risk of Explosion or Fire.**

Do not adjust the minimum flow rate of the valve below the minimum safe working rate of the appliance. This may cause gas leaks, which can lead to an explosion or fire, and may result in severe personal injury or death.

**IMPORTANT:** Refer to and follow any specific instructions issued by the appliance manufacturer with regards to servicing their equipment

The pressure regulator is adjustable and has been set to a specific customer requirement. If a different setting is desired, follow these instructions:

1. Shut off all gas to the appliance.
2. Turn the thermostat to the lowest setting or Off position.
3. Remove the pressure tap plug at the valve outlet or in the manifold pipe downstream of the valve (Figure).

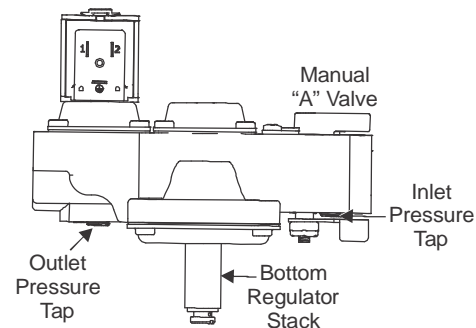

**Figure 7: G195 Redundant Combination Gas Valve Features**

4. Install a manometer or pressure gauge suitable for measuring desired orifice pressure.
5. Remove the seal screw at the end of the regulator stack.
6. Turn the gas on and place the thermostat at the highest setting.
7. Adjust the screw in the regulator stack to the desired reading on the manometer. (Turn clockwise to increase the outlet pressure and counterclockwise to reduce the outlet pressure.)
8. Reinstall the seal screw, which incorporates the proper size hole for venting to the atmosphere. (It may be necessary to cycle the valve several times to verify the desired outlet pressure.)
9. Turn off the gas supply and place the thermostat at the lowest setting.
10. Remove the pressure manometer and reinstall the pressure tap plug.
11. Turn the gas on and set the thermostat at the desired setting.
12. Before leaving the site, check for leaks at the pressure tap plug with a soap solution.

## Repairs and Replacement



### **CAUTION: Risk of Electric Shock.**

Disconnect power supply before making electrical connections to avoid electric shock.



### **WARNING: Risk of Explosion or Fire.**

Shut off the gas supply at the main manual shutoff valve before installing or servicing the G96. Failure to shut off the gas supply can result in the release of gas during installation or servicing, which can lead to an explosion or fire, and may result in severe personal injury or death.



**WARNING: Risk of Explosion, Fire, or Electric Shock.** Label all wires before they are disconnected when replacing or servicing the G195. Wiring errors can cause improper or dangerous operation and may result in an explosion, fire, or electric shock leading to severe personal injury or death.

Field repairs **must not** be made to the G195 valve. Any attempt to repair this assembly voids the manufacturer's warranty. For a replacement valve or valve accessories, contact the original equipment manufacturer or the nearest BASO Gas Products distributor.

## Maintenance Schedule

Preventive maintenance programs are an important part of maintaining optimum and safe function of your BASO products. Commercial cooking and other heating equipment can be a heavy cycling demand on gas safety controls.

The maintenance programs should include frequent checkout of the gas controls. Review the procedure as described in the setup and adjustments and check for leakage section of the instructions.

Exposure to water, chemicals, dirt, heat and grease can all contribute to premature shut down of the gas controls.

The frequency of the maintenance must be determined by the appliance manufacturer where the controls are installed and the end user for each individual application.

Things to consider when determining a preventive maintenance program:

- Number of cycles a gas control will see annually (more than 20,000 cycles). The gas control should be checked monthly.
- Gas controls used less than 20,000 cycles should be checked before every shutdown and restart process.
- Heavy grease, high heat, wash down exposure, corrosive environment areas should be checked with a higher frequency to prevent premature shutdown from rapid deterioration.

Simply doing a scheduled maintenance program will help remove the chances of a costly unexpected shutdown.

Field repairs **must not** be made to the G196 Series valve as this will void the manufacturer's warranty. Never try to replace a gas control unless you are an authorized licensed gas contractor. In all cases, use an authorized licensed gas contractor for any gas control replacement. For a replacement valve or valve accessories, contact the original equipment manufacturer or the nearest BASO Gas Products distributor.

## Technical Specifications

<b>Product</b>	G195 Series BASOTROL Combination Gas Valve with Manual Shutoff Valve			
<b>Maximum Operating Pressure</b>	0.5 psi (35 mbar)			
<b>Valve Body</b>	Aluminum			
<b>Permissible Ambient (Surface) Temperature</b>	Nitrile diaphragm:	CSA -20 to 175°F (-29 to 79°C) UL -20 to 140°F (-29 to 60°C)		
	Silicone diaphragm:	CSA -40 to 175°F (-40 to 79°C) UL -40 to 140°F (-40 to 60°C)		
<b>Conduit Connection Replacement</b>	SVC200 replaces wire leads SCV210 replaces conduit connector			
<b>Electrical Rating</b>	25 VAC, 50/60 Hz, 0.42 A 120 VAC, 60 Hz, 0.088 A			
<b>Regulator Adjustment Range</b>	Bottom Adjust Regulators:	3 to 6 in. W.C. (7.5 to 15 mbar) 8 to 12 in. W.C. (20 to 30 mbar)		
	Top Adjust Regulators:	3 to 6 in. W.C. (7.5 to 15 mbar) 6 to 12 in. W.C. (15 to 30 mbar)		
<b>Wiring Connections</b>	30 in. (762 mm) lead wires			
<b>Inlet Pipe Size</b>	1/2 in. NPT			
<b>Outlet Pipe Size</b>	3/8, 1/2, or 3/4 in. NPT			
<b>Pilot Outlet</b>	1/8 in.-27 NPT, left or right (1/4 in. cc also available)			
<b>Pressure Taps</b>	1/8 in.-27 NPT plugged inlet and outlet			
<b>Types of Gas</b>	Natural, Liquefied Petroleum (LP), and LP gas-air mixtures			
<b>Accessories</b>	Conversion Kits:	Natural gas to LP gas:	top adjust regulator bottom adjust regulator	Y71GF-4 Y71GF-3
		LP gas to natural gas:	top adjust regulator bottom adjust regulator	Y71QH-2 Y71QH-3
	Non-Regulation	top or bottom adjust regulator		Y71AA-5
<b>Packaging</b>	Bulk pack supplied to original equipment manufacturer (individual pack optional)			
<b>Bulk Pack Quantity</b>	18			
<b>Bulk Pack Weight</b>	39 lb (18 kg)			
<b>Agency Listing</b>	CSA Certificate Number 229521-1656041  UL File No. MH5939			
<b>Specification Standards</b>	ANSI Z21.78, CSA 6.20 UL 429			

Performance specifications are nominal and conform to acceptable industry standards. All agency certification of BASO products is performed under dry and controlled indoor environmental conditions. Use of BASO products beyond these conditions is not recommended and may void the warranty. Product must be protected if exposed to water (dripping, spraying, rain, etc.) or other harsh environments. The original equipment manufacturer or end user is responsible for the correct application of BASO products. Consult BASO Gas Products LLC for questionable applications. BASO Gas Products LLC shall not be liable for damages or product malfunctions resulting from misapplication or misuse of its products.

Refer to the G195 Series BASOTROL Combination Gas Valve with Manual Shutoff Valve Product Bulletin (BASO-PB-G195) for necessary information on operating and performance specifications of this product.



BASO Gas Products LLC

450 East Horseshoe Road  
PO Box 170  
Watertown, WI 53094  
1-877-227-6427 (1-877-BASOGAS)

[www.baso.com](http://www.baso.com)  
Printed in U.S.A.

G195 Model Rev. B Series BASOTROL Combination Gas Valve with Manual Shutoff Valve