



120 VAC Direct Spark Ignition Control

QUICK REFERENCE GUIDE

The 120 VAC Direct Spark Ignition (DSI) control module is designed for use in all types of gas-fired appliances. The microprocessor based design allows for safety monitoring and precise timing of operation sequences. A diagnostic LED provides the operator with feedback on the operating state of the ignition and provides diagnostic feedback in the event of an error condition.

The following is an overview of the 120 VAC Series Ignition Control and is intended for use by Certified Service Technicians only.

APPLICATIONS

- Commercial Cooking
- Gas Furnaces
- Boilers
- Water Heaters
- Other Gas-Fired Appliances

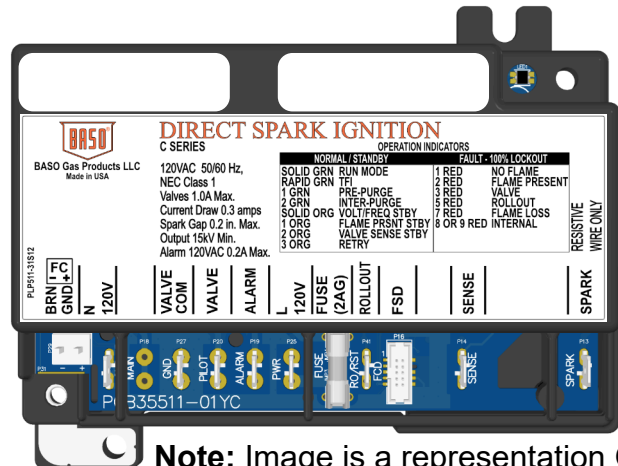

Note: Image is a representation ONLY. Actual ignition models may differ.

FEATURES

- Microprocessor Based Design
- System Diagnostics
- Local/Internal or Remote/External Flame Sensing
- Flame Current Test Header
- 4 Mounting Hole Positions, 2 for Direct Mounting to NEC 4-in Junction Box
- Built-in Burner Ground
- Voltage/Frequency Monitoring
- Alarm Output (Normally Open Contact)

AGENCY CERTIFICATIONS



UL 60730-1, UL 60730-2-5
File: M2926 Software conforms to UL60730 Requirement Component Recognized System (US & Canada)



EN298:2022
File: 748250



EN298:2022
File: 704826



AS 4625:2008 (R2016)
GSC 765577

TECHNICAL SPECIFICATIONS

| | |
|--|---|
| Input Voltage | 120 VAC (102-138 VAC) 50/60 Hz |
| Input Current | 0.5 A nominal + valves |
| Gas Valve Contact Rating | 1 A Main @ 120 VAC |
| Alarm Output | 0.2 A @ 120 VAC |
| Operating Temperature | -40 to 176°F (-40 to 80°C) |
| Flame Detection Means | Flame Rectification |
| Flame Detection Type | Local/Internal or Remote/External |
| Minimum Flame Current | 0.07 microamperes |
| Flame Failure Response Time | 1.0 second maximum |
| Ignition Source | 15kV High voltage spark, capacitive discharge |
| Maximum Spark Gap | 0.2 in. (5.1 mm) |
| High Voltage Cable | 48 in. (1219 mm) max., rated 15kV min. (Resistive recommended) |
| Flame Sense Cable | 48 in. (1219 mm) max. (Shielded recommended) |
| Spark | 60 sparks/second |
| Humidity | 0% to 95% RH (non-condensing) |
| Gas Types | Natural, LP, or Manufactured |
| Trials Before 100% Shutoff / Recycle Attempts [*],^{***} | 1 - 9 trials or Continuous |
| Trial for Ignition Time / Safety Time [*] | 4, 5, 8, 10, 11, 15, 20 or 21 seconds |
| Pre-Purge Time [*],^{**} | 0, 4, 5, 10, 15, 20, 30, or 60 seconds |
| Inter-Purge Time [*] | 0, 5, 10, 15, or 30 seconds |
| Retry (Automatic Reset) [*],^{***} | 0, 5, or 60 minutes |
| Lockout Recovery | Power cycle |

* For custom timings, contact BASO Gas Products

** Pre-Purge Time cannot exceed Inter-Purge Time on CE, UKCA, or AGA approved models

*** Automatic reset, Continuous trials are not allowed on CE, UKCA, or AGA approved models

| | |
|---|---|
|  WARNING | <p>Read Quick Reference Guide completely before use.</p> <p>This ignition control must be wired in accordance with all local, national and regional electrical codes.</p> |
|---|---|

| | |
|---|---|
|  WARNING | <p>Operation outside specifications may result in failure of ignition control and other equipment with potential risk of personal injury.</p> |
|---|---|

| | |
|---|---|
|  WARNING | <p>EMC emission requirements of the burner control system need to be verified after incorporation into the end use appliance.</p> |
|---|---|

**WARNING**

The voltages used and generated by this product have shock hazard potential. Wiring and initial operation checks must be performed by a qualified service technician.

**CAUTION**

Label all wires prior to disconnection when servicing ignition control. Wiring errors may cause improper and dangerous operation. A functional checkout should always be performed after modifying wiring.

WIRING CONNECTIONS

| LABEL | TERMINAL TYPE | DESCRIPTION |
|-----------------------------------|---------------------------|--|
| FC - + | 2 Pin Connector | Flame current test pins for measuring microamps with DMM using μA setting |
| BRN GND | Mounting Tab (lower left) | Burner/Equipment ground connection * |
| N 120V | 1/4" Male Quick Connect | 120 VAC common (neutral) connection |
| VALVE COM | 1/4" Male Quick Connect | Gas valve common (neutral) connection |
| VALVE | 1/4" Male Quick Connect | Gas valve connection |
| ALARM *** | 1/4" Male Quick Connect | Alarm signal connection |
| L 120V | 1/4" Male Quick Connect | 120 VAC power (line) connection |
| FUSE *** | Fuse Holder Clips | Ignition control fuse |
| ROLLOUT or RESET or N 120V *** | 1/4" Male Quick Connect | Rollout or reset switch or spare N 120V connection |
| FSD *** | 10 Position Header | Header to connect BASO Flame Sense Display Module |
| SENSE | 1/4" Male Quick Connect | Flame sensor connection (dual rod, remote/external) ** |
| SPARK | 1/4" Male Quick Connect | High voltage sparking electrode connection |

* If the existing system has a burner ground wire it needs to be connected to the burner ground mounting tab on the ignition with a No. 6 or No. 8 machine screw to ensure a proper burner ground.

** For dual rod (Remote/External) flame sensing, connect the flame sense wire from the burner/igniter to the sense terminal. For single rod (Local/Internal) flame sensing, there will be no terminal/connection required.

*** Some terminals are optional features and will not be populated on all ignition controls.

SPARK CABLE: The spark cable must be noise suppression (resistive) type rated for at least 15kV and must not be in continuous contact with a metal surface. If a remote flame sense probe is used, the sense wire should be separated from the Spark cable by a **minimum** of 6.25mm (1/4"). The Spark and Sense wire should be isolated from any pipe, other wiring, or accessories.

DO NOT WRAP OR TIE FLAME SENSE CABLE TO SPARK CABLE. Doing so may interfere with the proper operation of the ignition control.

WIRING CONNECTIONS (CONT.)

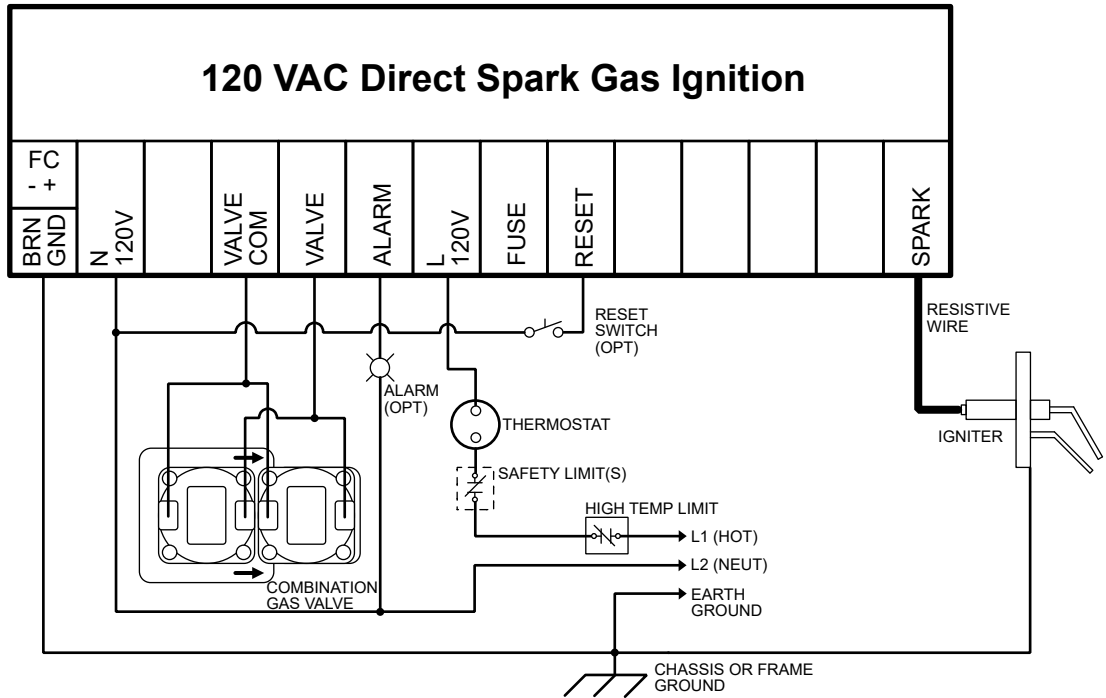

Figure 1: Wiring for 1 Rod Flame Sense used for Local (Internal) Sense with Wiring for a Reset Switch

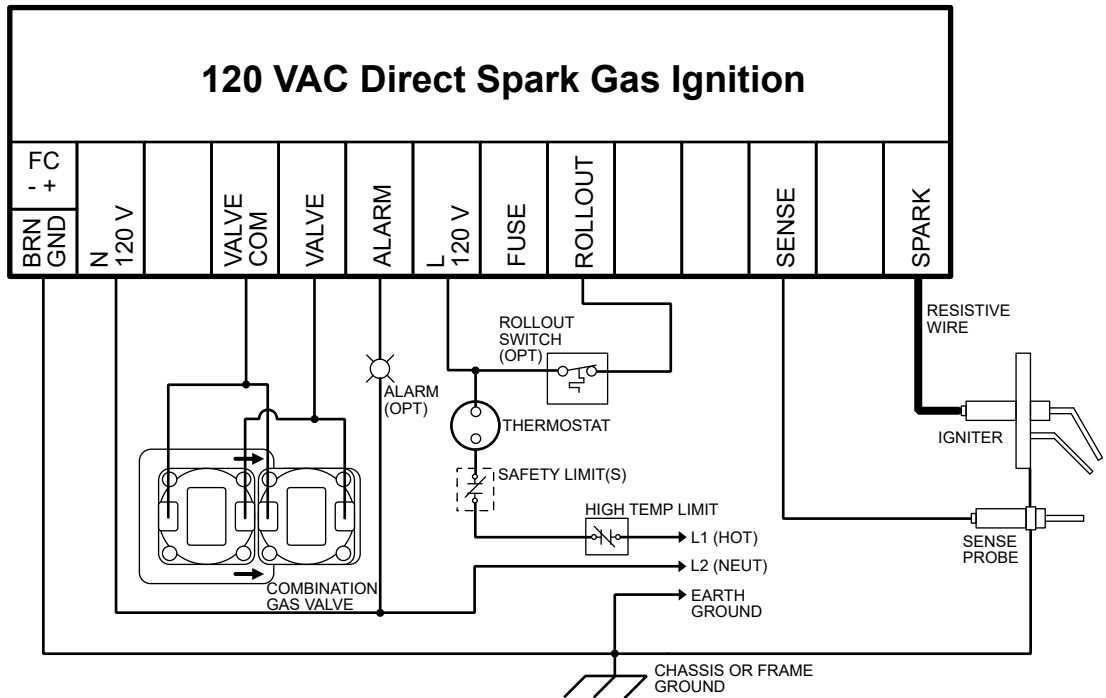

Figure 2: Wiring for 2 Rod Flame Sense used for Remote (External) Sense with Wiring for a Rollout Switch

**WARNING**

Do not install the control in areas that can be exposed to dripping water, steam cleaning, heavy dust, grease, or corrosive chemicals. If the controls may be subjected to these types of environments, use a NEMA 4 rated enclosure to protect the ignition control.

**CAUTION**

If not properly protected from harsh environments, the control may prematurely fail or malfunction. Temperatures outside of rated temperatures may damage the ignition control or cause it to malfunction. Ensure ambient temperatures around the ignition do not exceed the rated temperature for the ignition control.

LED STATUS AND TROUBLESHOOTING

The ignition control has a multi-colored LED (GREEN, ORANGE, RED) that will flash different colors and codes to indicate the status of the ignition control. The table below lists the various flash codes of the ignition control to aid in troubleshooting the ignition control.

GREEN LED INDICATIONS OF NORMAL OPERATION

| FLASH | INDICATION |
|-------------|--------------------------|
| SOLID GREEN | RUN (Flame, Valve On) |
| RAPID GREEN | TFI (Trial for Ignition) |
| 1 GREEN | Pre-Purge |
| 2 GREEN | Inter-Purge |

ORANGE LED INDICATIONS OF STANDBY ERROR CONDITIONS

| FLASH | INDICATION | ERROR TYPE |
|--------------|------------------------|------------|
| SOLID ORANGE | LINE VOLTAGE/FREQUENCY | STANDBY |
| 1 ORANGE | FLAME PRESENT | STANDBY |
| 2 ORANGE | VALVE SENSE | STANDBY |
| 3 ORANGE | RETRY | STANDBY |

RED LED INDICATIONS OF ERROR CODES

| FLASH | INDICATION | ERROR TYPE |
|------------|-------------------------|--------------|
| 1 RED | NO FLAME IN TRIAL TIME | 100% LOCKOUT |
| 2 RED | FLAME PRESENT AFTER 30s | 100% LOCKOUT |
| 3 RED | VALVE FAULT | 100% LOCKOUT |
| 5 RED | ROLLOUT SWITCH FAULT | 100% LOCKOUT |
| 7 RED | REPETITIVE FLAME LOSS | 100% LOCKOUT |
| 8 or 9 RED | INTERNAL CONTROL FAULT | 100% LOCKOUT |
| 10 RED | POWER LOSS FAULT | 100% LOCKOUT |
| SOLID RED | RESET TRIGGERED | 100% LOCKOUT |

NOTE: An LED flash is characterized by 0.5 seconds on followed by 0.5 seconds off. The full flash code is shown and then repeated after a 1 second pause.

TROUBLESHOOTING GUIDE

| PROBLEM | POTENTIAL CAUSE(S) |
|--|--|
| Ignition control does not power up | <ul style="list-style-type: none"> - Ensure proper 120 VAC wiring connections to ignition control - Faulty thermostat - Safety limits tripped - Faulty ignition control |
| Control LED is blinking RED | - Ignition control is in error state. Refer to previous table to determine error code, and refer to the Operational Flowchart in the installation instructions. |
| No spark during TFI time | <ul style="list-style-type: none"> - Faulty spark electrode wiring - Ensure spark gap is set within specified values - Faulty control |
| Burner does not light during TFI time | <ul style="list-style-type: none"> - Ensure proper wiring connections to valve - Faulty gas valve - Faulty control |
| Burner lights but gas valve turns off after TFI time | <ul style="list-style-type: none"> - Weak flame or flame not in contact with the spark electrode or flame sensor. Ensure the tip of the flame sensor is in the flame. For proper sensing, the rod tip must be 3/8" (10mm) to 1/2" (13mm) in the flame. See illustration below for proper flame sensor positioning. (Figure 3) - Dirty or corroded flame sensor - Ensure proper flame sensor wiring - Poor burner ground. |

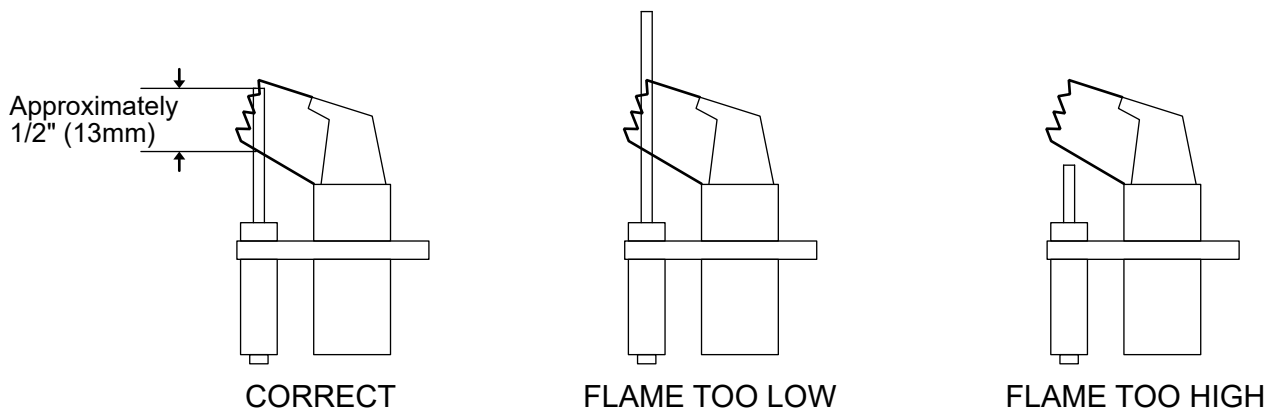

Figure 3: PROPER FLAME SENSOR POSITION

FLAME CURRENT MEASUREMENT

Flame current of the ignition control can be measured using a standard microammeter by touching the meter leads to the 2-pin header on the ignition control labeled FC as shown in the illustration below. (Figure 4)

- Flame current must be measured with the flame lit and the main gas flowing.
- Set the meter to DC μ A scale.
- Ensure the meter leads are positioned correctly (+ / -).
- The typical flame sense current measurements are in the range of 0.4 to 1.2 μ A DC.

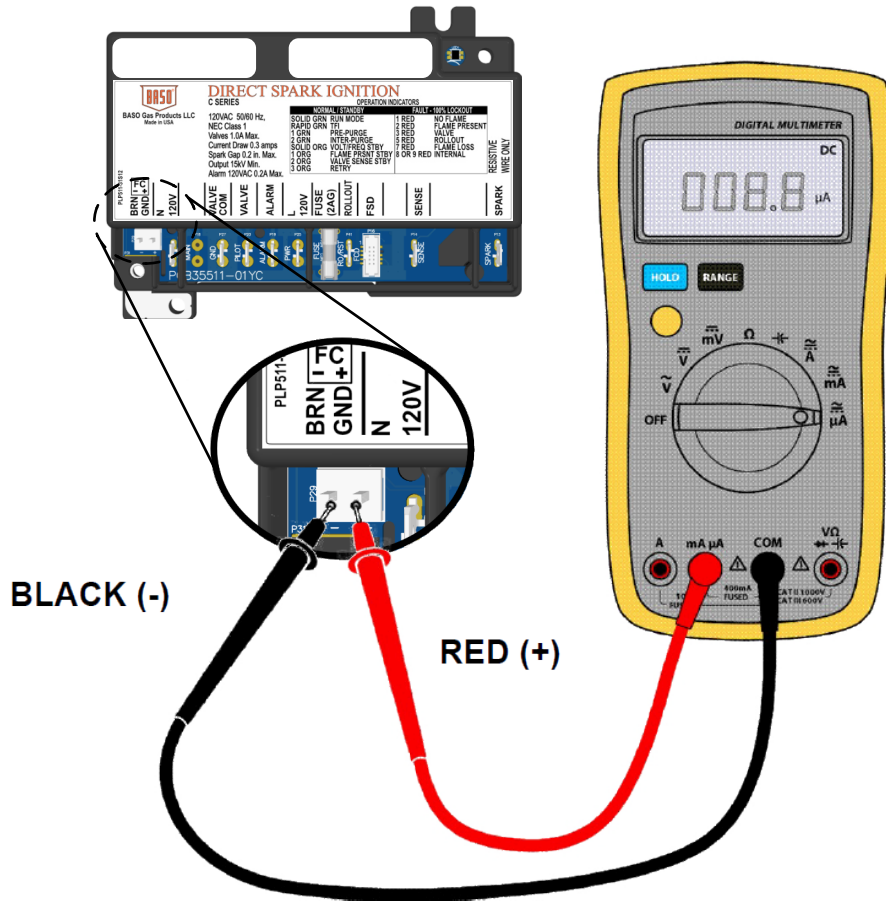

Figure 4: Microammeter Connection

IMPORTANT: Preventative maintenance programs are an important part of maintaining optimum and safe function of your BASO Products. Any attempt to repair this assembly voids the manufacturer's 2-year warranty. For a replacement module, contact the original equipment manufacturer or nearest BASO Gas Products distributor.

Note: For more information on BASO ignition controls, complete installation instructions, and other products, please visit us at www.baso.com.

450 East Horseshoe Road
PO Box 170
Watertown, WI 53094
1-877-277-6427 (1-877-BASOGAS)

www.baso.com
Published in U.S.A.